

MAN 4166770
Rev. A 05-2011



MODEL:
544873D
MATAWAY OVERSEEDER



TECHNICAL MANUAL

CALIFORNIA

Proposition 65 Warning

Diesel engine exhaust and some of its constituents are known to the State of California to cause cancer, birth defects and other reproductive harm.

⚠ WARNING

The engine exhaust from this product contains chemicals known to the State of California to cause cancer, birth defects or other reproductive harm.

Californie Proposition 65 Avertissement

Les échappements des moteurs diesel et certains de leurs composants sont reconnus par l'Etat de Californie pour être cancérigènes, provoquer des défauts congénitaux et d'autres dangers en matière de reproduction.

⚠ AVERTISSEMENT

L'émission du moteur de ce matériel contient des produits chimiques que l'Etat de Californie considère être cancérigènes, provoquer des défauts congénitaux et d'autres dangers en matière de reproduction.

**California Advertencia
de la Proposicion 65**

El estado de California hace saber que los gases de escape de los motores diesel y algunos de sus componentes producen cáncer, defectos de nacimiento y otros daños en el proceso de reproducción humana.

⚠ ADVERTENCIA

El estado de California hace saber que los gases de escape de este producto contienen productos químicos que producen cáncer, defectos de nacimiento y otros daños en el proceso de reproducción humana.

CALIFORNIA

Proposition 65 Warning

Battery posts, terminals, wiring insulation, and related accessories contain lead and lead compounds, chemicals known to the State of California to cause cancer and birth defects or other reproductive harm.

WASH HANDS AFTER HANDLING.

MATAWAY OVERSEEDER

IMPORTANT MESSAGE

Thank you for purchasing this Ryan product. You have purchased a world class product, one of the best designed and built anywhere.

This machine comes with a Technical Manual containing safety, operation, parts, maintenance and service information. The useful life and good service you receive from this machine depends to a large extent on how well you read and understand this manual. Treat your machine properly, lubricate and adjust it as instructed, and it will give you many years of reliable service.

Your safe use of this Ryan product is one of our prime design objectives. Many safety features are built in, but we also rely on your good sense and care to achieve accident-free operation. For best protection, study the manual thoroughly. Learn the proper operation of all controls. Observe all safety precautions. Follow all instructions and warnings completely. Do not remove or defeat any safety features. Make sure those who operate this machine are as well informed and careful in its use as you are.

See a Ryan dealer for any service or parts needed. Ryan service ensures that you continue to receive the best results possible from Ryan's products. You can trust Ryan replacement parts because they are manufactured with the same high precision and quality as the original parts.

Ryan designs and builds its equipment to serve many years in a safe and productive manner. For longest life, use this machine only as directed in the manual, keep it in good repair and follow safety warnings and instructions. You'll always be glad you did.

Schiller Grounds Care, Inc.
One Bob Cat Lane
Johnson Creek, WI 53038-0469

TABLE OF CONTENTS	FIGURES	PAGE
SAFETY.....		2-6
SAFETY AND OPERATION DECALS.....		7
SET-UP.....		8
CONTROLS.....		9
OPERATION.....		10-13
MAINTENANCE		14-15
ADJUSTMENTS.....		16-21
BELT REPLACEMENT		22-23
SEED HOPPER CHART		23
SERVICE.....		24-27
STORAGE		28
TRANSPORTING		29
SPECIFICATIONS.....		30
PARTS SECTION.....		31
CHASSIS.....	FIGURE 1	32, 33
HANDLE ASSEMBLY.....	FIGURE 2.....	34, 35
CLUTCH ASSEMBLY AND CONTROL	FIGURE 3.....	36, 37
ENGINE AND DRIVE ASSEMBLY	FIGURE 4.....	38, 39
TRANSMISSION	FIGURE 5.....	40, 41
GUARDS.....	FIGURE 6.....	42, 43
HOPPER DRIVE.....	FIGURE 7.....	44, 45
HOPPER FRAME	FIGURE 8	46, 47
HOPPER AND DISC ASSEMBLY	FIGURE 9.....	48, 49
REEL	FIGURE 10.....	50, 51

NOTICE !!!

Unauthorized modifications may present **extreme** safety hazards to operators and bystanders and could also result in product damage.

Schiller Grounds Care, Inc. strongly warns against, rejects and disclaims any modifications, add-on accessories or product alterations that are not designed, developed, tested and approved by Schiller Grounds Care, Inc. Engineering Department. Any Schiller Grounds Care, Inc. product that is altered, modified or changed in any manner not specifically authorized after original manufacture—including the addition of “after-market” accessories or component parts not specifically approved by Schiller Grounds Care, Inc.—will result in the Schiller Grounds Care, Inc. Warranty being voided.

Any and all liability for personal injury and/or property damage caused by any unauthorized modifications, add-on accessories or products not approved by Schiller Grounds Care, Inc. will be considered the responsibility of the individual(s) or company designing and/or making such changes. Schiller Grounds Care, Inc. will vigorously pursue full indemnification and costs from any party responsible for such unauthorized post-manufacture modifications and/or accessories should personal injury and/or property damage result.



This symbol means:
ATTENTION!
BECOME ALERT!

Your safety and the safety of others is involved.

Signal word definitions:

The signal words below are used to identify levels of hazard seriousness. These words appear in this manual and on the safety labels attached to Schiller Grounds Care, Inc. machines. For your safety and the safety of others, read and follow the information given with these signal words and/or the symbol shown above.

DANGER

DANGER indicates an imminently hazardous situation which, if not avoided, **WILL** result in death or serious injury.

WARNING

WARNING indicates a potentially hazardous situation which, if not avoided, **COULD** result in death or serious injury.

CAUTION

CAUTION indicates a potentially hazardous situation which, if not avoided, **MAY** result in minor or moderate injury. It may also be used to alert against unsafe practices or property damage.

CAUTION

CAUTION used without the safety alert symbol indicates a potentially hazardous situation which, if not avoided, **MAY** result in property damage.

Schiller Grounds Care, Inc.

One Bobcat Lane
Johnson Creek, WI 53038 U.S.A
Phone: 920-699-2000
Fax: 920-699-3683

MODEL NUMBER

SERIAL NUMBER

MODEL NUMBER: This number appears on sales literature, technical manuals and price lists.

SERIAL NUMBER: This number appears only on your unit. It contains the model number followed consecutively by the serial number. Use this number when ordering parts or seeking warranty information.

PREPARING FOR SAFE OPERATION

Operator preparation and training

Read the Operation & Safety Manual

- If an operator or mechanic cannot read, it is the owner's responsibility to explain this material to them. If any portion of this material is unclear, contact your factory representative for clarification.
- Become familiar with the safe operation of the equipment, operator controls and safety signs. Know how to stop the engine and attachments quickly in an emergency. Do not operate or allow another person to operate this machine if there are any questions about safety.
- All operators and mechanics should be trained. The owner is responsible for training the users.
- Wear appropriate clothing, including long trousers and safety goggles or safety glasses with side shields when operating. Do not operate barefoot or wearing open sandals. Long hair, loose clothing or jewelry may get tangled in moving parts.
- Wear hearing protection.
- Never allow underage children, unskilled or improperly trained people to operate this equipment. Local regulations can restrict the age of the operator.
- Keep warning labels and this operator's manual legible and intact. Replacement labels and manuals are available from the factory.
- Do not operate machine while under the influence of drugs or alcohol.
- The owner/user can prevent and is responsible for accidents or injuries occurring to themselves, other people or property.



Site preparation and circumstances

- Evaluate the terrain to determine what accessories and attachments are needed to properly and safely perform the job. Only use accessories and attachments approved by the manufacturer.
- Clear the area to be dethatched/seeded of objects such as rocks, toys, wire or other debris that may be picked up or thrown by the machine.
- Be sure the area is clear of pets and people, especially young children. Never assume they will remain where you last saw them. Stop the machine if any enter the area.
- Operate only in daylight or in good artificial light.
- Do not operate wet grass as tires may lose traction.

Machine preparation

- Check operator presence interlock system and brake operation. Adjust or repair any problems before using.
- Do not tamper with or defeat safety devices. Keep guards, shields and interlock safety devices in place and in proper working condition. They are for your protection.
- Keep all fasteners such as nuts, bolts and pins well secured.
- Visually inspect blades, blade bolts and the cutter assembly for wear or damage. Replace worn or damaged blades and bolts to preserve balance.
- Verify that machine and attachments, if any, are in good operating condition.
- Do not engage blades until ready to dethatch/seed.

OPERATING SAFELY

In general

- Use extra care when loading or unloading the machine into a trailer or truck.
- Slow down and use caution when making turns and crossing roads and sidewalks. Stop blades if not dethatching/seeding.
- Do not run the engine in an enclosed area where dangerous carbon monoxide fumes can collect.
- Stop operation if someone approaches.
- Keep housing service openings closed when dethatching/seeding.
- Do not turn sharply. Use care when reversing.
- Use counter-weight(s) or wheel weights when suggested in the operator's manual.
- Never leave a machine running unattended. Always turn off blades, set parking brake (if equipped), stop engine and remove key (if equipped) before leaving the operator's position.

Starting

- Start only according to instructions in this manual or on the machine.
- Before attempting to start the engine, make sure:
 - the master clutch is disengaged;
 - the traction drive is in NEUTRAL.
- When starting the engine, make sure hands and feet are clear of the blades.
- Do not start the machine while standing in front of the discharge chute or with the chute directed at someone.
- Do not engage master clutch at full throttle. Throttle to idle or lowest possible engine speed.
- Do not change engine governor settings or overspeed the engine. Operating the engine at excessive speed can increase the hazard of personal injury.

Interrupting operation

- Before leaving the operator's position:
 - Park on level ground.
 - Disengage the master clutch.
 - Shut off the engine.
- Disengage the master clutch and wait until the blades quit rotating:
 - before raising blade assembly;
 - when not dethatching/seeding;
 - for transport;
 - when crossing surfaces other than grass.
- Disengage the master clutch, stop the engine, :
 - before refueling;
 - before making height adjustment unless the adjustment can be made from the operator's position.
- Disengage the master clutch, stop the engine, allow the blades to come to a complete stop, and disconnect the spark plug wire:
 - before clearing blockages;
 - before checking, cleaning or working on the machine;
 - before performing maintenance or repair;
 - after striking a foreign object. Inspect the machine for damage and make repairs before restarting;
 - if the machine begins to vibrate abnormally: shut off machine immediately. Inspect and make repairs as needed before restarting;
 - except for repairs or adjustments as specifically noted, such as for carburetor adjustment, where the engine must be running. Keep hands and feet clear of moving parts in these circumstances.
- Reduce the throttle setting during engine shut-down and, if the engine is provided with a shut-off valve, turn the fuel off at the conclusion of operation.

MANEUVERING SAFELY

In general

- Slow down before turning.
- Do not operate in reverse unless absolutely necessary. Always look behind and down for small children and pets before and during backing.
- Be aware when approaching blind corners, shrubs, trees, tall grass or other objects that may obscure vision.
- If tires lose traction, disengage the blades. If on a slope, head downhill.



Slope Operation

- Slopes are a major factor in loss-of-control and tipover accidents that sometimes lead to severe injury or death. All slopes require extra caution.
- Do not operate on slopes if uneasy or uncertain. Ultimate responsibility for safe operation on slopes rests with the operator.
- Do not operate excessively steep slopes.
A slope is too steep if:
 - The machine must be crabbed (turned partially sideways uphill) to drive across the slope.
 - The machine turns downhill going across the slope.
 - You are uneasy about being on the slope.
- With walk behind machines, operate across slopes, not up and down.
- Avoid starting or stopping on a slope. If tires lose traction, disengage the blades and proceed slowly straight down the slope.
- Keep all movement on the slopes slow and gradual. Do not make sudden changes in speed or direction.
- Do not turn on slopes unless necessary, and then turn slowly and downhill when possible.
- Stay away from slopes if the ground is loose or if caught in the rain during operation.
- Use lower speeds on a slope to avoid stopping or shifting.
- Remove obstacles such as rocks, tree limbs etc.
- Avoid driving over obstacles such as ruts, holes, rocks and roots whenever possible. Be alert to dips and rises. Uneven terrain can overturn a machine or cause it to slide. Tall grasses can hide obstacles.

- Do not operate near dropoffs, ditches or embankments. The machine could suddenly turn over if a wheel runs over the edge or an edge caves in.
- Follow the manufacturer's recommendations for wheel weights or counterweights to improve stability.
- Do not operate on slopes when grass is wet. Reduced traction could cause sliding.

MAINTENANCE AND STORAGE SAFETY

In general

- Maintain machine according to manufacturer's schedule and instructions for maximum safety and best results.
- Park machine on level ground.
- Never allow untrained personnel to service machine.
- Adjust or repair only after the engine has been stopped and the blades have quit rotating.
- Replace parts if worn, damaged or faulty. For best results, always replace with parts recommended by the manufacturer.
- Disconnect spark plug wire(s) before making any repairs.
- Do not dismantle the machine without releasing or restraining forces which may cause parts to move suddenly.
- Provide adequate support, e.g. jackstands for lifted machine or parts if working beneath.
- Do not put hands or feet near or under rotating parts.
- Clean up spilled oil or fuel thoroughly.
- Replace faulty mufflers.
- To reduce fire hazards, keep the engine, muffler, and fuel storage area free of grass, leaves, debris buildup or grease.

Blades

- Only replace blades. Never straighten or weld them.
- Keep other persons away from blades.



Fuel

- Gasoline and diesel fuels are flammable; gasoline vapors are explosive. Use extra care when handling.
- Store only in containers specifically designed for fuel.
- When refueling or checking fuel level:
 - Stop the engine and allow to cool;
 - Do not smoke;
 - Refuel outdoors only;
 - Use a funnel;
 - Do not overfill;
 - If fuel is spilled, do not attempt to start the engine until the spill is cleaned up and vapors have cleared.



Storage





- Stop the engine and allow to cool before storing.
- Drain the fuel tank outdoors only.
- Store fuel in an approved container in a cool, dry place.
- Keep the machine and fuel containers in a locked storage place to prevent tampering and to keep children from playing with them.
- Do not store the machine or fuel container near heating appliances with an open flame such as a water heater or other appliance with a pilot light.
- Keep gasoline storage area free of grass, leaves and excessive grease to reduce fire hazard.
- Clean grass and debris from cutting units, drives, mufflers and engine to help prevent fires.

Prevent sparks from static electricity during fueling:

- Do not fill containers in a vehicle or on a truck or trailer bed with a plastic liner. Fill containers on the ground away from the vehicle.
- When practical, remove gas powered equipment from the truck or trailer and refuel it on the ground. If equipment must be refueled on the truck or trailer, refuel from a portable container rather than a dispenser nozzle.
- Keep the dispenser nozzle in contact with the rim of the fuel tank or container opening until fueling is complete. Do not use a nozzle lock-open device.
- Replace caps on fuel cans and tanks securely.

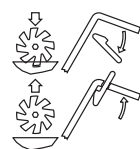
MATAWAY OVERSEEDER

SAFETY AND OPERATION DECALS

	<p>WARNING</p> <p>BEFORE STARTING OR SERVICEING: Read and understand the Operator's Manual and labels</p> <ul style="list-style-type: none"> -Be sure machine is in safe operating condition. -Move Master Clutch to Disengaged position. -Raise blades. <p>BEFORE LEAVING OPERATOR POSITION: -Move Master Clutch to Disengaged position.</p> <ul style="list-style-type: none"> -Stop engine. 	 <p>Blades Raise/Lower</p>	<p>MASTER CLUTCH</p>  <p>Disengaged</p>  <p>Wheels Engaged</p>  <p>Wheels and Blades Engaged</p> <p>4167491</p>
---	---	---	--

	<p>DANGER</p> <p>Rotating blades can cut</p> <ul style="list-style-type: none"> -Keep hands and feet from under machine -Stop engine before servicing <p>4163888</p>
--	---

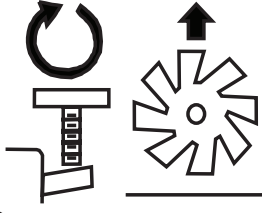
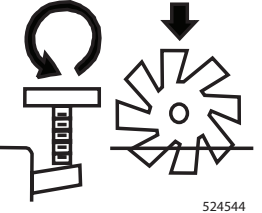
	 <p>524544</p>
---	--

<p>WARNING</p>

<p>ROTATING PARTS CAN ENTANGLE, CUT AND CRUSH</p> <ul style="list-style-type: none"> -Keep hands away from moving parts. -Do not operate without guards and shield in place. -Disconnect spark plug and read manual before performing any service or maintenance. <p>4163592</p>

CAUTION

Do not operate this equipment until you have read the **CONTROLS** and **OPERATION** sections of this manual thoroughly.

To prevent injury, use an adequate lifting device (i.e., hoist, or fork lift) to remove unit from pallet.

1. Remove the crate top and sides.

WARNING

Banding is under tension and may snap back when cut. Wear eye protection and stay clear when cutting the band.

2. Remove and discard banding attaching the Mataway Overseeder to the pallet.

Ensure the engine is level, then check the engine oil level. Top off if necessary. See the adjustment section for setting blade height.

THROTTLE (A)

Move throttle lever forward to increase engine speed. Move the lever rearward to decrease engine speed.

LIFT LEVER (B)

Raises and lowers the frame mounted reel. Pull the lever back and down to lower the reel. Pull the lever up and forward until it locks over center to raise the reel.

OPERATOR PRESENCE LEVER (C)

Must be held against the handle bar whenever the clutch control is engaged or the engine will stall (the engine can be started without holding the operator presence lever, if the clutch control is disengaged).

CLUTCH CONTROL (D)

Engages the clutch for both the drive transmission and reel rotation. The machine may be pushed when the drive is disengaged. Engaging the drive when the machine is off acts as a parking brake.

REEL CONTROL LEVER (E)

Must be pulled back against the clutch control handle for the reel clutch to be engaged.

Pull the Reel Control Lever back against the clutch control and push the clutch control forward to engage both the drive clutch and the reel clutch. Push the clutch control forward without pulling back the reel control lever to engage the drive clutch ONLY. Pull the clutch control all the way back until it locks over center to disengage both clutches.

CHOKE (F)

Move cable control to right to apply choke. Move choke control to left to remove choke.

ENGINE SWITCH (G)

Turn the engine switch to the "ON" or "RUN" position before starting. Turn the engine switch to the "OFF" position to stop the engine.

FUEL VALVE (H)

Move to the "ON" position to allow fuel to flow to the engine. Close the fuel valve when the engine is not being operated.

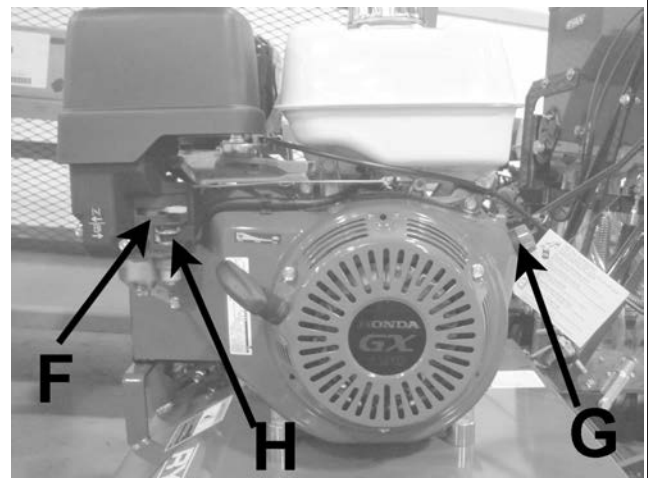
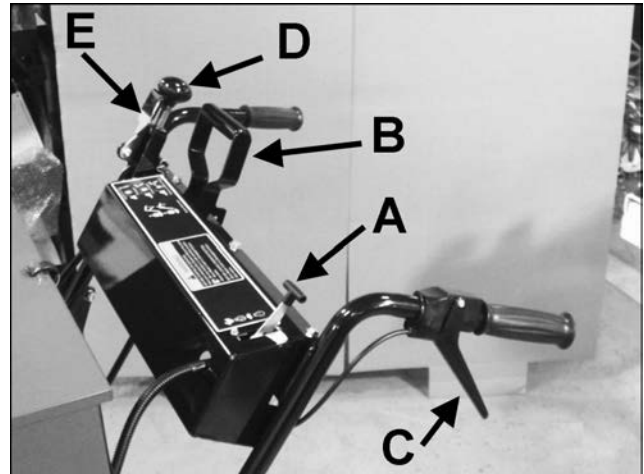

PRE-OPERATION CHECK LIST OPERATOR'S RESPONSIBILITY

- Review and follow all safety rules and safety decal instructions.
- Check that all safety decals are installed and in good condition. Replace if damaged.
- Check to make sure all shields and guards are properly installed and in good condition.
- Check that all hardware is properly installed and secured.
- Check to be sure engine is free of dirt and debris. Pay particular attention to the cooling fins, governor parts and muffler. Clean air intake screen. Check air cleaner; service if necessary.
- Clean area around oil fill dipstick. Remove dipstick and check to be sure oil is in operating range (between marks on dipstick). Add oil if necessary but **DO NOT OVERFILL**. Install dipstick assembly firmly until cap bottoms out on tube. Dipstick assembly must be secured into fill tube when engine is running.
- Check all lubrication points and grease as instructed in manual.
- Perform a functional check of the Operator Presence system each time you operate the unit.

WARNING

Gasoline is extremely flammable and highly explosive under certain conditions. BE SURE to install fuel cap after refueling.

Fill fuel tank with good quality, clean, unleaded regular gasoline to the level recommended by the engine manufacturer.

TO CHECK OR ADD FUEL:

- Use a funnel to avoid spilling.
- Do it outdoors.
- Do not smoke.
- Stop the engine; allow to cool.
- Do not overfill.
- Clean up spilled fuel.

WARNING

To prevent injury from thrown blades, do not operate unit with reel blades that are cracked, badly bent, missing, or in any abnormal condition.

To prevent injury from rotating blades, keep hands or feet from beneath the unit.

Before operating, check area to be worked and remove any object(s) which may present a safety hazard and/or damage the equipment.

Engage the reel ONLY when you are in the operator's position.

BEFORE STARTING THE ENGINE

- Be familiar with controls, how each functions and what each operates.
- Ensure the engine is level, then check the engine oil level. Add oil if necessary.
- Open the fuel valve **H**.

STARTING THE ENGINE

1. Move the lift lever to the raised position.
2. Disengage the clutch control. (The engine will not start if the clutch control is engaged).
3. Move the throttle lever midway between fast and slow.
4. Turn the engine switch **G** to the "ON" position.

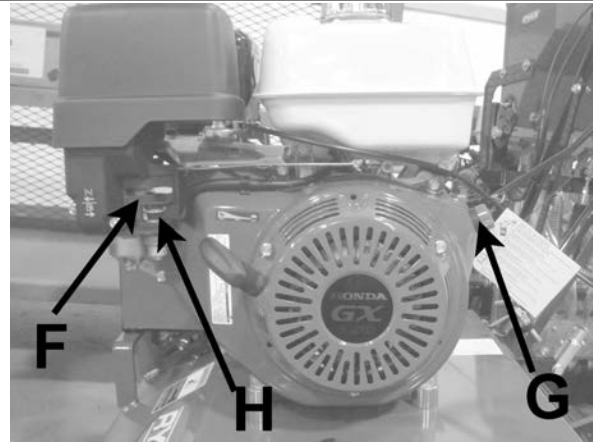

5. Use the choke as required to start a cold engine. Choke control **F** is located on the front of the engine.
5. Stand at side of unit placing left foot on top of housing and slowly pull the recoil starter until just past compression. Return starter handle, pull firmly with a smooth, steady motion to start.

OVERSEEDER OPERATION

1. Adjust reel to desired cutting depth, not to exceed 1/4" (6mm) maximum. See adjustment section.

NOTE: Cutting depth exceeding 1/4" (6 mm) may be too deep for most seed and may prevent germination.

2. Make a test run to check for desired blade penetration. Adjust if necessary.

NOTE: Low tire pressure may cause uneven reel penetration. Maintain correct tire pressure to eliminate this possibility (refer to the Tire Pressure section in the maintenance section, for recommended tire pressure).

3. Set the feed control cam **A** on the hopper according to the "Overseeder Seed Chart" located on page 23. Fill the hopper with seed.

4. Start the engine. Hold the operator presence lever against the handle.

5. Pull back on the reel control lever and push the clutch control forward to engage both the reel and drive clutches. Adjust the throttle to the desired walking speed.

6. Lower the reel **after** the unit is in motion, the seed gate opens automatically as the reel is lowered.

NOTE: To prevent damage to the turf, the unit should be in motion and the clutch control engaged **before** lowering reel onto the turf.

Never cross hard surfaces or objects (sidewalks, driveways, stepping stones, etc.) while the reel is down and/or engaged.

7. After each pass across the turf, raise the reel, disengage the clutch control and position the unit manually for the next pass (this will help prevent damage to the turf). Make all passes across the turf at uniform speed. Slightly overlap the area previously seeded to ensure complete coverage.

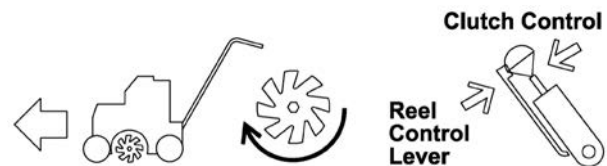
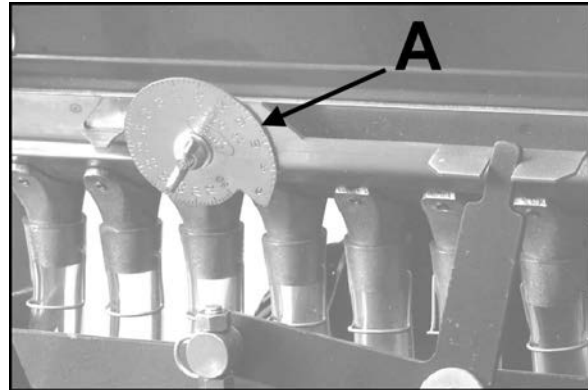

CROSSHATCH OVERSEEDING

Making two passes over the same area with the feed cam set at half the desired seed flow rate will provide faster fill in.

Make the first set of passes (parallel to each other) over the area in the normal manner but at half the seed feed rate.

Cover the same area again, but make the second set of passes at a 45° angle across the first set of passes, again at half the seed rate.

This will lay down the seed in a diamond pattern, resulting in better distribution and faster cover after germination.

DETHATCHING

For the de-thatching operation, make sure there is no seed in the hopper, **seed gate will still open during use.**

1. Adjust reel to desired cutting depth. See adjustment section.
2. On fine turf such as a golf greens make a few test runs on similar turf. This will allow preliminary adjustments to be made before entering greens (etc.) and help eliminate the possibility of turf damage due to misadjustments.

NOTE: Low tire pressure may cause uneven reel penetration. Maintain correct tire pressure to eliminate this possibility (refer to the Tire Pressure section in the maintenance section, for recommended tire pressure).

3. Start the engine. Compress and hold the operator presence lever.
4. Pull back on the reel control lever and push the clutch control forward to engage both the reel and drive clutches. Adjust the throttle to the desired walking speed.
5. Lower the reel **after** the unit is in motion, the seed gate opens automatically as the reel is lowered.

NOTE: To prevent damage to the turf, the unit should be in motion and the clutch control engaged **before** lowering reel onto the turf.

Never cross hard surfaces or objects (sidewalks, driveways, stepping stones, etc.) while the reel is down and/or engaged.

6. After each pass across the turf, raise the reel, disengage the clutch control and position the unit manually for the next pass (this will help prevent damage to the turf). Make all passes across the turf at uniform speed.

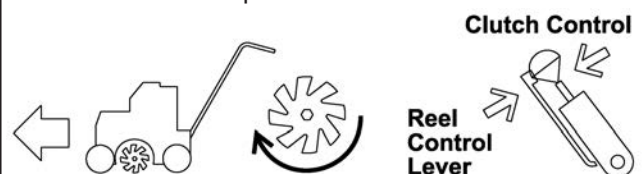

DAILY MAINTENANCE

Operator Presence System

For the engine to run, the Operator Presence Lever must be held when the Clutch Control is engaged. Start the engine and engage the clutch control without holding the Operator Presence Lever. The engine should kill.

Repair the machine before using if the Operator Presence System does not kill the engine.

Blades:

Check for damage. Replace any broken, cracked or otherwise damaged blades. Do not weld or straighten blades.

Hardware:

Tighten any nuts and bolts that are found loose. Replace any broken or missing cotter pins. Repair any other problems before operating.

Engine:

Change oil after the first 5 hours. See engine manual for change intervals and oil specifications. See engine manual for air cleaner service intervals and service procedure.

Tire Pressure:

Keep tires inflated to 25 lbs/in² (1.76 kg/cm²). Improper tire inflation can cause rapid tire wear, poor traction and uneven penetration.

⚠ WARNING

Explosion Hazard

Small tires pressurize very rapidly. Use a hand pump or short bursts from a pressurized source to avoid overfilling. Do Not exceed the recommended pressure.

LUBRICATION

The Mataway has 7 grease fittings.

1. Wipe each fitting before and after lubrication.
2. Use a good quality Lithium based grease.
3. Lubricate equipment after every 8 hours of use and before long storage periods.

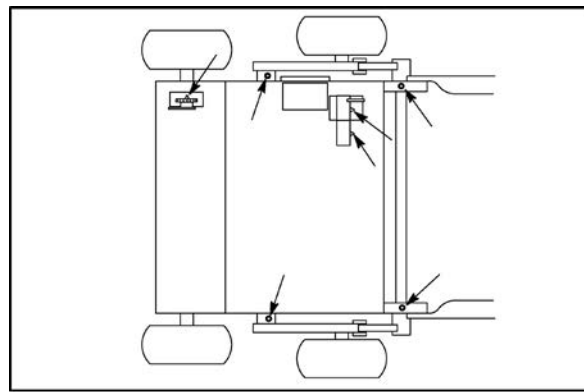

REEL BLADE REPLACEMENT

1. Remove reel. See Reel Removal and Installation

NOTE: Note how the blades and spacers are arranged on the reel and the direction of the blades **before** disassembly so that it can be reassembled in the same manner.

2. On the end of the shaft opposite the pulley, loosen the set screw in the locking collar **A** on the reel shaft. Insert a punch in the small hole on the collar and use a hammer to tap the collar clockwise until it's loose (approx. 1/4 turn). Remove the collar and remove the pillow block and bearing **B**.
3. Loosen the socket head screw **C** in the reel nut **D** and remove the reel nut from the shaft.
4. Slide the blades and spacers off of the shaft.
5. Reassemble the reel with new blades.

NOTE: When reassembling the reel, it is important to start and end with a spacer. **DO NOT** assemble with a blade next to the shaft nut.

6. Make sure the socket head screw **C** in the reel nut **D** is just "snug" or about 1 to 2 ft.-lb. (1.5 - 3 N-m). Screw the nut onto the reel shaft and torque to 80 + 10 ft.-lb. (108 + 13 N-m). Make sure enough spacers are used to prevent the reel nut from contacting the shoulder of the hexagonal section of the shaft. Tighten the socket head screw to 10 to 12 ft.-lb. (13-16 N-m).
7. Install the pillow block with bearing **B** on the shaft. Slide the pillow block on until the outside edge of the block is 5/8" (16mm) from the end of the shaft.
8. The pillow block **B** must also be perpendicular to the shaft. To check this, hold a ruler **G** against the first blade **H** and across the edge of the pillow block. Rotate the pillow block by hand. If the edge of the pillow block does not appear to wobble (move back and forth) the pillow block is perpendicular.

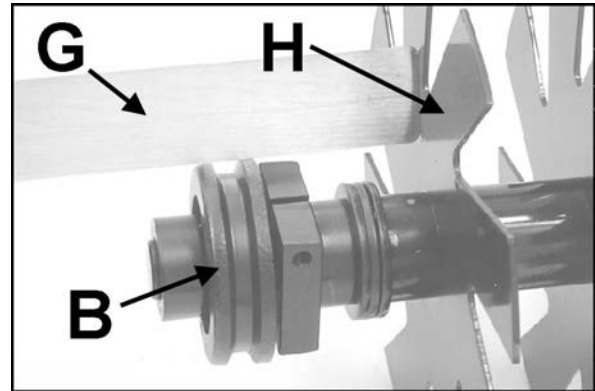
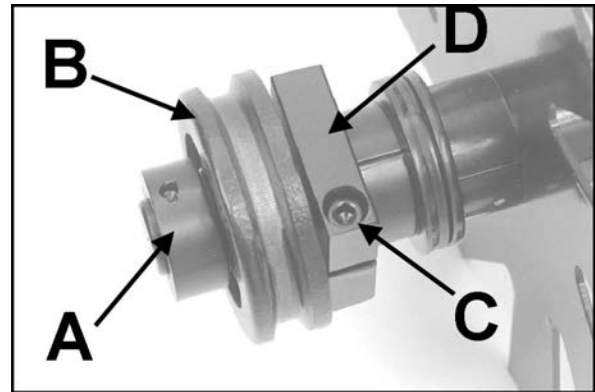

9. Install the locking collar against the bearing by tapping it counterclockwise approx. 1/4 turn and tightening the set screw.
10. After the reel has been reinstalled (refer to the section on Reel Removal and Installation) readjust the blade height.

After 4 hours of use, check reel nut for proper torque. The torque value for the reel nut is 80 ft.-lbs. + 10 ft.-lbs. (108 + 13 N-m).

MATAWAY OVERSEEDER DEPTH ADJUSTMENT

Make initial depth adjustment with the unit on a level surface.

1. Lower the unit to the operating position.
2. Loosen lock nut **H**.
3. Turn adjusting screw **G** until the blades just touch the surface.
4. Raise the unit to the transport position. Turn the adjustment screw **G** 3-1/2 turns counter-clockwise to get 1/4" (6mm) of blade penetration.
5. Tighten lock nut **H** after adjustment.

Make a test run to check adjustment.
Increasing depth decreases ground clearance.

NOTE: This unit is designed for a maximum of 1/4" (6mm) turf penetration. Some seeds will not germinate at depths exceeding 1/4". Exceeding 1/4" (6mm) penetration will shorten belt life.

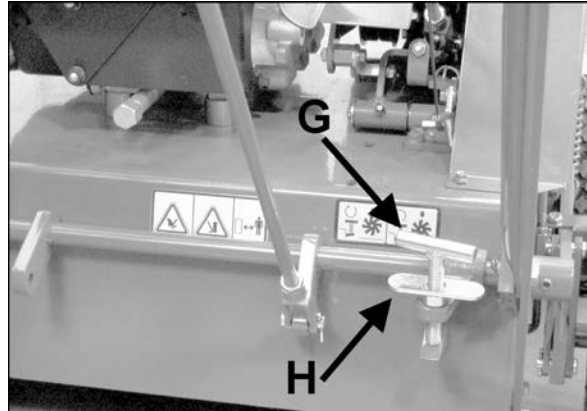

NOTE: Never cross hard surfaces or objects, (sidewalks, stepping stones, etc.) with reel blades down and/or engaged.

Low tire pressure may cause uneven reel penetration. Maintain correct tire pressure to eliminate this possibility (refer to the Tire Pressure section in the maintenance section, for recommended tire pressure).

HOOK AND CABLE ADJUSTMENT

1. Remove seed hopper drive cover, seed hooper drive belt, and transmission belt cover.
2. Loosen the nut **D** and bolt **E** securing the latch **A**. Slide the latch in the slot so that the latch hook **C** captures the reel idler assembly when the clutch control is disengaged. When only the drive clutch is engaged, the latch should hold the reel idler assembly back far enough that the reel belts will not engage. Retighten the hook mounting hardware.
3. After the LATCH has been adjusted, Loosen the two jam nuts **B** at the top of the cable. Adjust the bottom nut to take up any slack in the cable. Be careful not to overtighten the cable or the LATCH may not hold the reel idler assembly. Use the top nut to lock the lower nut into place.

SEED HOOPER BELT ADJUSTMENT

NOTE: The seed hopper belt is tensioned by a spring loaded idler. No adjustment is necessary.

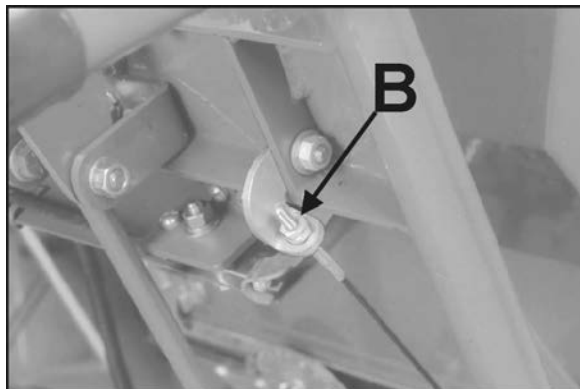
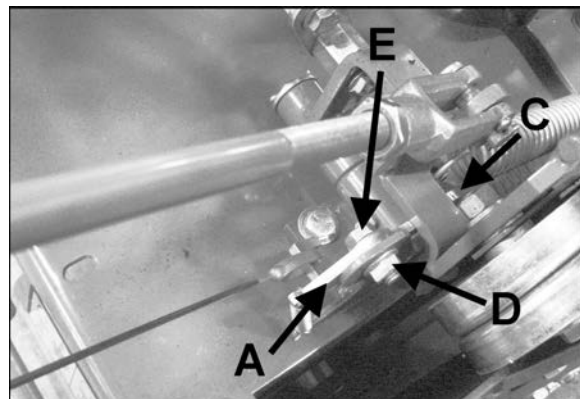

ADJUSTMENT FOR REEL AND DRIVE BELTS

Belt tension may need adjusting due to run in and normal wear. Inspect belts daily to ensure proper operation of the unit.

NOTE: Reel and drive belt adjustments are guidelines only. The reel drive belts should engage without slipping and disengage completely. The drive belt should engage without slipping and disengage so that the unit will not creep.

Remove seed hopper drive cover, seed hopper drive belt, and transmission drive belt cover.

REEL DRIVE BELT.

Engage the reel drive clutch. Measure the distance between the reel drive belts and the forward edge of the idler assembly belt stop. Measurement **D** should be 3/4" (19 mm). If the Reel belt requires adjustment the Transmission Drive Belt must also be adjusted. (Figure 1)

TRANSMISSION DRIVE BELT

Engage the drive clutch. Measure the distance from the top edge of the idler pulley **F**, to the top edge of the drive belt **G**. The measurement **E** should be approximately 1-1/4" to 2" (32 to 50 mm). The Transmission Belt may be adjusted independent of the Reel Drive Belt. (Figure 2)

REEL DRIVE BELT ADJUSTMENT:

1. Loosen the transmission mounting plate **A** and chain idler sprocket hardware. Slide the transmission/mounting plate assembly as far rearward as it will go to provide slack in the transmission drive belt.
2. Clean the underside of chassis to allow movement of the engine and loosen the engine mounting hardware.
3. Loosen the set screw in the locking collar **C** on the drive shaft. Insert a punch in the small hole in the collar and use a hammer to tap the collar clockwise (opposite direction of engine rotation) until it's loose (approx. 1/4 turn).
4. Loosen the hardware securing the mounting plate **B** (supporting the reel drive pulley) and the pillow block.

5. Make sure the springs are in place on the drive belt idler arm and the reel belt idler arm.

NOTE: Belt cover removed for clarity.

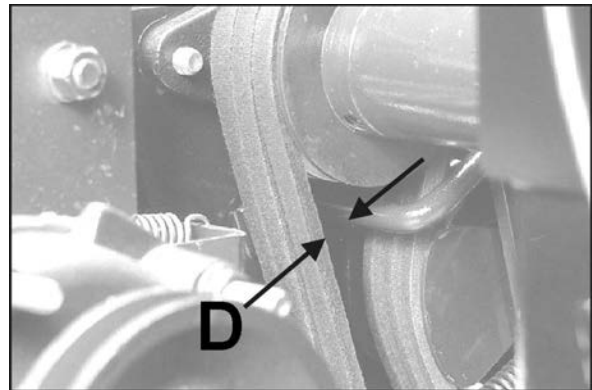

FIGURE 1

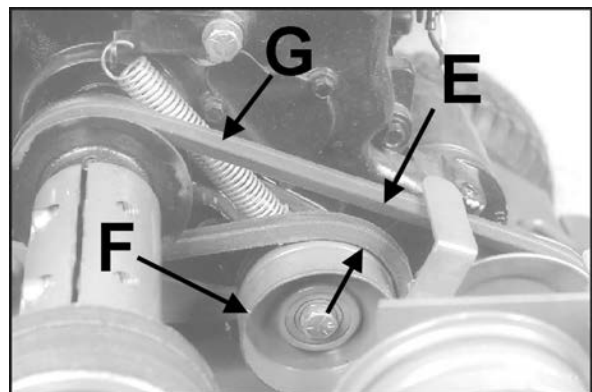
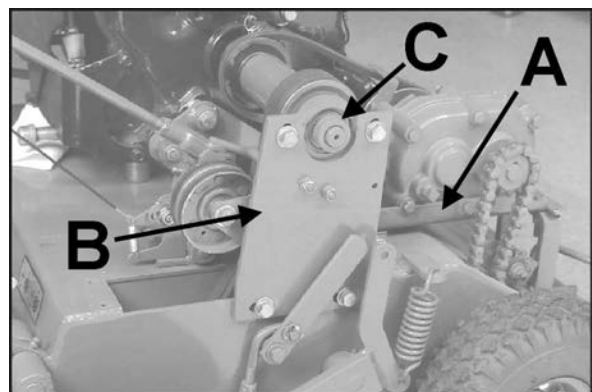

FIGURE 2



6. Square the engine with the chassis. If measurement **D**(Figure 1) is over 3/4" (19mm) slide the engine forward as necessary to obtain proper measurement **D**. If measurement **D** is under 3/4" (19mm) slide the engine rearward as necessary to obtain proper measurement. Tighten the engine mounting screws.
7. Align the mounting plate **L** so that it is perpendicular to the chassis and the pillow block bearing is centered on the coupler shaft. Tighten the two plate mounting screws **H** at the bottom of the plate.
8. Align the pillow block bearing with the coupler shaft so that there is no vertical or side load on the shaft and tighten the pillow block mounting hardware. Torque the pillow block screws to 25 ft.-lbs. (34 N·m).
9. Tighten locking collar **K** on engine coupler shaft. Rotate collar counterclockwise on pillow block shoulder. Using hammer and punch, lock collar into position. Tighten set screw in collar **K**.
10. Engage reel drive clutch. Check the clearance from the idler pulley **M** to the belt stop **N** bolted to the mounting plate, clearance should be a minimum of 1/16" (2 mm). If necessary, loosen the belt stop hardware **O** and reposition it. Tighten hardware.
11. Complete adjustment process by performing steps 12-17 of the Transmission Belt Adjustment.

TRANSMISSION DRIVE BELT ADJUSTMENT:

12. Perform step one of the Reel Belt Adjustment.
13. Slide the transmission assembly forward until measurement **E** is approximately 1-1/4" to 2" (32-50mm).
14. Tighten transmission mounting hardware securely. Slide chain idler sprocket against the drive chain until there is 1/8" to 1/4" (3 to 6mm) play in the chain opposite the sprocket and secure hardware.

NOTE: Belt cover removed for clarity.

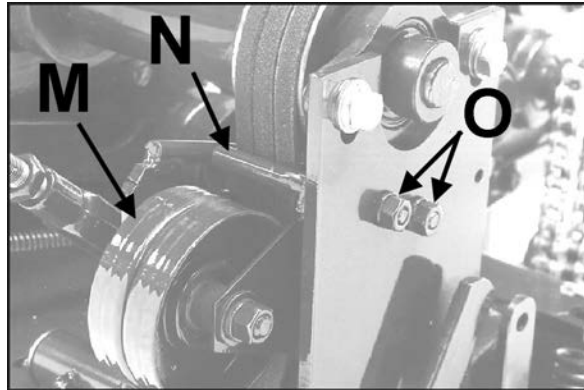
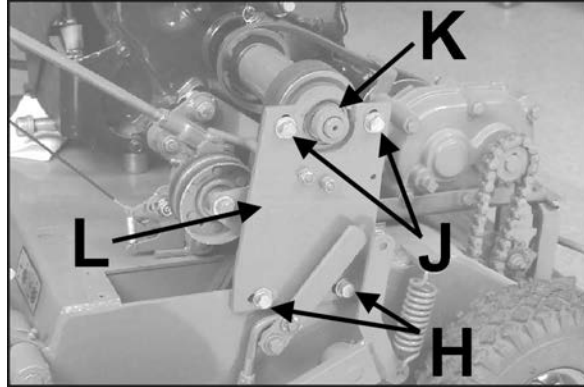

15. Check transmission belt alignment with a straight edge. Loosen the set screw on the transmission pulley and slide it in or out to achieve proper alignment.
16. Check operation of reel and transmission belt drives. The drive belts should engage without slipping and disengage so that the unit will not creep. Readjust if necessary.
17. Reinstall transmission belt cover, seed hopper drive belt, and seed hopper drive cover. Check clutch control over-center and belt stop tension adjustments.

CLUTCH CONTROL OVER-CENTER:

NOTE: The clutch control should positively lock over-center in the disengaged position. Adjust rod length if necessary.

18. Remove seed hopper drive cover, seed hopper drive belt, and transmission belt cover.
19. Loosen the jam nut on top of the clevis at the bottom of the clutch lever **E** (below).
20. Remove the cotter pin **A** and clevis pin **B**, and the two bushings **C** on the control handle. Turn the rod to shorten or lengthen the rod as required and reattach the rod to the handle with the clevis pin.
21. Check to ensure over-center locking action. When proper locking action is obtained, completely reassemble control handle and tighten jam nut.
22. Reinstall transmission belt cover, seed hopper drive belt, and seed hopper drive cover.

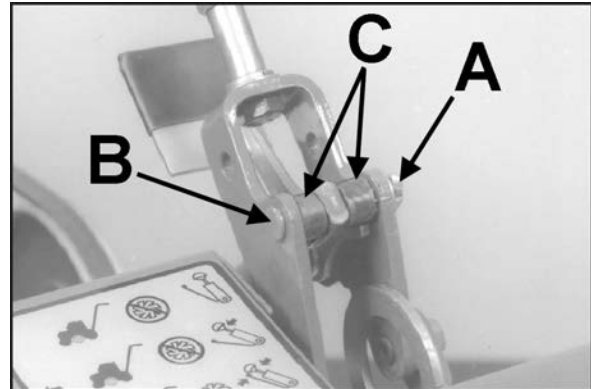

BELT STOP TENSION:

The reel drive belts should be held firmly but not pinched severely with reel drive lever disengaged.

NOTE: Over tight belt stops will cause undue wear on reel drive belts.

23. Remove seed hopper drive cover, seed hopper drive belt, and transmission belt cover.
24. Engage clutch control. Loosen the jam nut on screw **D** in the reel belt idler assembly. Adjust belt stop tension by turning screw **D** in or out.
25. Disengage the clutch lever. Check the belt stop adjustment. Readjust if necessary.
22. Reinstall transmission belt cover, seed hopper drive belt, and seed hopper drive cover.

NOTE: The belt stops should be perpendicular to the reel belts and parallel to each other. Make sure reel drive idler pulley is centered and aligned over reel drive belts.

NOTE: Belt cover removed for clarity.

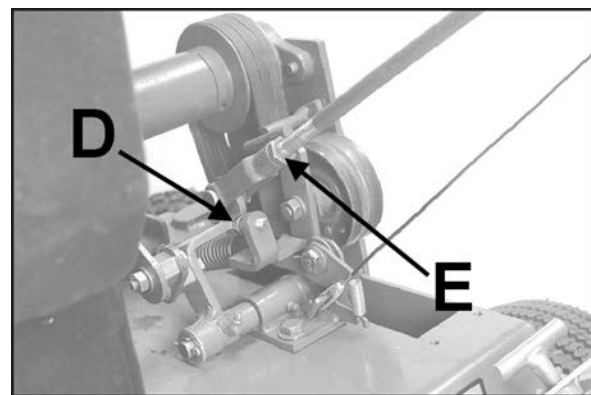

HOPPER DRIVE PULLEY SPROCKET ADJUSTMENT

Remove the seed hopper drive cover and transmission drive cover. Make sure the seed hopper drive belt is installed. Raise and lower the reel using the Reel Lift Lever, and check to make sure the sprocket **C** on the inside of the hopper drive pulley properly engages the drive chain **D** from the transmission.

1. If the pulley sprocket **C** does not align with the chain **D**, loosen set screw in drive sprocket **E** on the transmission and move the sprocket in or out on its shaft to align the chain with the pulley sprocket.
2. If the pulley sprocket is aligned with the chain but does not engage the chain fully, raise the reel and check the chain tension for the proper 1/8" to 1/4" (3 to 6mm) play.
3. If the chain tension is correct, lower the reel and loosen the nut **G** on the hopper pulley adjustment rod **H** until the sprocket **C** fully engages the chain.
4. To make sure the pulley sprocket fully disengages the chain, raise the reel, and check for clearance **F** of approximately 1/8" (3 mm) between the sprocket and chain.
5. Reinstall the transmission drive cover, and seed hopper drive cover.

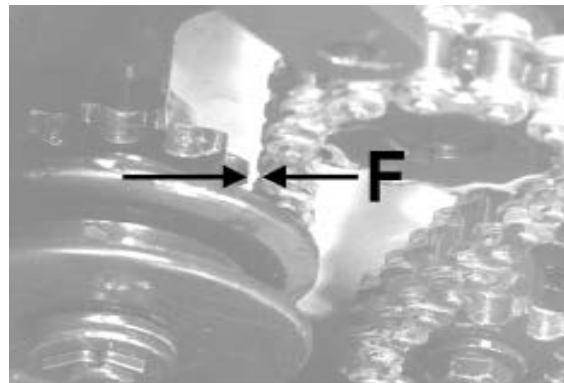
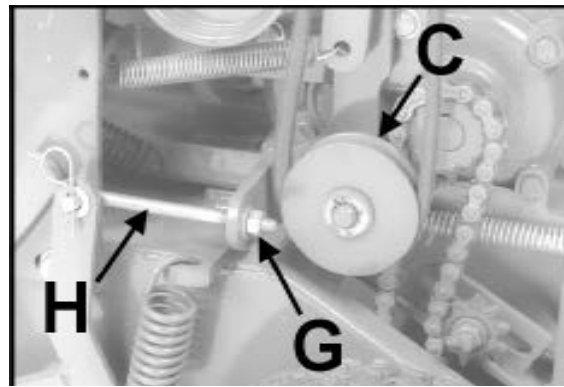
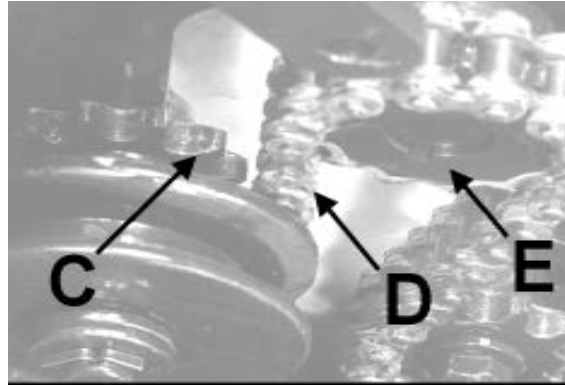

DISC ALIGNMENT

1. Tip unit forward and place on jack stands. Check the disc/blade alignment by placing a straight edge **C** against the concave side of either the fifth or sixth disc **A** and the corresponding blade **B** on the reel. The straight edge should lie flat against both disc and blade.

CAUTION

Use adequate jack stands when supporting the unit. Failure to do so may result in personal injury.

2. The discs can be aligned with the blades by loosening the two locking collars just inside the bearings at either end of the disc shaft. Loosen the set screws and tap the collar clockwise (with hammer and punch) to unlock, then move the entire shaft until the discs align with the blades. Lock the collars against the bearings and tighten the set screws.

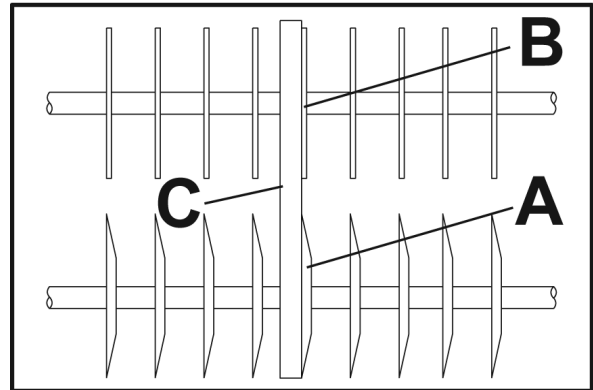

REEL BELT AND DRIVE BELT REPLACEMENT

NOTE: Reel belts are serviced in matched sets of three. When replacement is required, replace all three belts. It is a good idea to replace all belts (drive and reel) on the unit at the same time.

1. Remove the seed hopper drive cover, seed hopper drive belt and transmission drive cover.
2. Tilt the unit forward and support the rear of the chassis with jack stands.

CAUTION

Use adequate jack stands when supporting the unit. Failure to do so may result in personal injury.

3. Remove the lower belt guard from under the chassis and remove the reel. See reel removal and installation. Remove the jack stands and lower the unit.
4. Loosen the set screw in the locking collar **K** on the drive shaft. Insert a punch in the small hole in the collar and use hammer to tap the collar clockwise (opposite direction of engine rotation) until it's loose (approx. 1/4 turn). Remove the collar.
5. Remove the bolts **H** securing the mounting plate **L**. Remove plate and the pillow block **J** (leave the pillow block attached to the mounting plate).
6. Remove all three reel belts.

NOTE: Inspect the drive belt to the transmission after the reel belts have been removed. Replacing the drive belt now will save work and down time.

7. Install new belts (matched set of three).
8. Before reinstalling the mounting plate **L**, loosen but do not remove the pillow block **J**.
9. Slide the pillow block bearing onto the shaft and loosely mount the plate to the chassis. Adjust the mounting plate **L** side-to-side so that there is no side load on the drive shaft. Tighten the mounting plate hardware **H**.
10. Reinstall the locking collar against the bearing. Tighten locking collar by rotating counterclockwise on pillow block shoulder. Using punch and hammer, lock collar into position. Tighten set screw.
11. Adjust the pillow block up and down until it is centered on the shaft. Tighten the pillow block hardware.

NOTE: Belt covers removed for clarity.

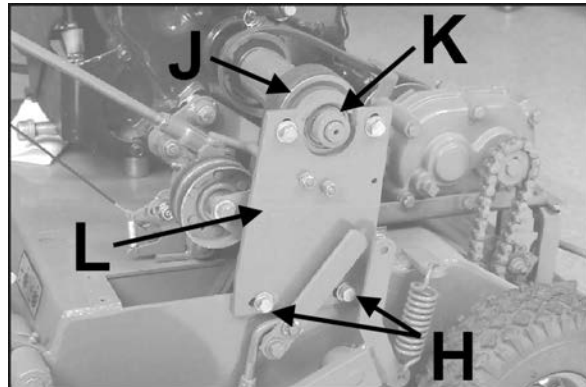

12. Rotate the drive shaft by hand to make sure there is no side load.

NOTE: Excessive side load on the shaft may cause engine crankshaft failure.

13. Check the reel belt pulley alignment. The measurement **A** should be 5/8" (16mm). If adjustment is required, loosen the set screw in the pulley and move the pulley in or out on the shaft.

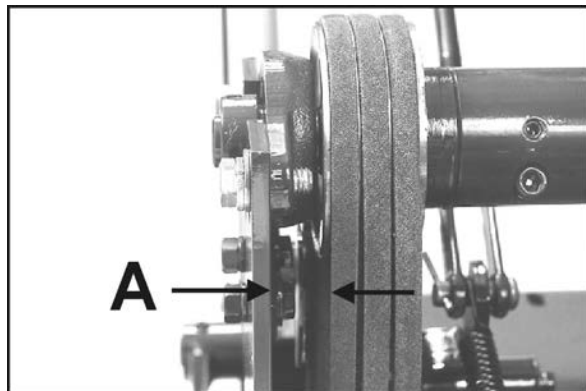

NOTE: The pulley is secured to the shaft by set screw and key. It may need to be tapped with a hammer for adjustment. Use a plastic, rubber, lead or leather head hammer to avoid damaging the pulley.

14. Support the unit on jack stands and reinstall the reel and belt guard beneath the chassis.

NOTE: Belts should be tight when the reel and drive are engaged and loose enough to slip when they are disengaged.

15. Reinstall transmission belt cover, seed hopper drive belt and seed hopper drive cover.

MATAWAY OVERSEEDER

BELT REPLACEMENT

SEED HOPPER DRIVE BELT REPLACEMENT

NOTE: Belt covers removed for clarity.

1. Remove the seed hopper drive cover.
2. Roll old belt off hopper drive pulley **A**.
3. Wrap new belt around drive pulley **C** and idlers **B**, and roll onto hopper drive pulley **A**.
4. Re-install seed hopper drive cover.

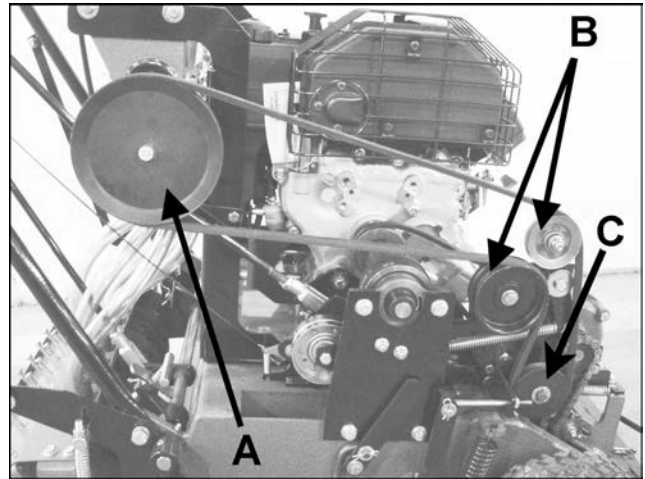

OVERSEEDER SEED CHART																	
Pounds of Seed per 1000 sq feet @ 2.5 Mph																	
Seed		Seeder Setting															
Type	Brand	5	10	15	20	25	30	35	40	45	50	55	60	65	70	75	80
Bentgrass	Penneagle	0.4	1.1	2.0	3.2	4.5											
	Penncross	0.2	0.7	1.3	2.0	3.0	4.3										
Kentucky Blugrass	Aspen		0.1	0.3	0.4	0.8	1.3	2.0	2.7	3.7	4.9	6.8	8.5				
	Rugby		0.1	0.3	0.6	1.4	1.9	3.2	4.3	6.1	7.9	10.7					
	Parade		0.1	0.3	0.6	1.2	1.9	1.0	3.8	5.3	7.0	9.0					
Fescue	Scal Dis Hard				0.1	0.3	0.5	1.0	1.3	1.9	2.7	3.9	5.4	7.2			
	Ruby Creeping Red				0.1	0.2	0.3	0.5	0.8	1.0	1.5	2.2	3.0	4.1	5.3	6.2	
	Galway Tall				0.1	0.2	0.5	0.7	1.2	1.8	2.6	3.8	5.3	7.1	9.0		
Perennial Ryegrass	Pennefine							0.4	0.7	1.2	1.7	3.3	4.4	6.6	7.4	9.2	
	Del Ray						0.6	1.1	1.5	2.3	3.2	5.0	6.7	8.6	10.6		
Mixture	Athletic Pro Turf		0.1	0.2	0.3	0.6	0.9	1.6	2.3	3.7	4.6	7.0	10.0				
	Overseeder 11		0.1	0.2	0.3	0.6	1.0	1.7	2.5	3.4	5.0	6.8	9.0				

TIRE PRESSURE

Keep the tires to the recommended pressure. Improper inflation will shorten the life of the tires and cause unsatisfactory operation.

Tires.....4.10 / 3.50 - 4, 2-ply
Tire Pressure.....24 to 26 PSI (165 to 179 kPa)

CAUTION

Due to low air volume of tires, over-inflation can be reached in a matter of seconds. To prevent explosion, check air pressure with air gauge before filling the tire. Fill to recommended air pressure, and Do Not exceed the recommended pressure.

CHAIN REPLACEMENT

1. Remove the seed hopper drive cover, seed hopper drive belt, and transmission drive cover.
2. Loosen the drive chain idler sprocket **B**.
3. Remove connecting link **C** and chain **D**.
4. Install new chain and connecting link.
5. Adjust the idler sprocket to allow approximately 1/8" (3 mm) to 1/4" (6 mm) of play in the chain (check for play on the straight section of chain opposite the sprocket). Tighten the idler sprocket hardware.

NOTE: Proper chain tension is essential. A tight chain will impose excessive bearing loads. A loose chain will cause noisy operation and chain pulsations, which may result in irregular sprocket speed and abnormal chain and sprocket wear.

6. Lubricate the fitting on the idler sprocket.
7. Reinstall the transmission belt cover, seed hopper drive belt, and seed hopper drive cover before using the unit.

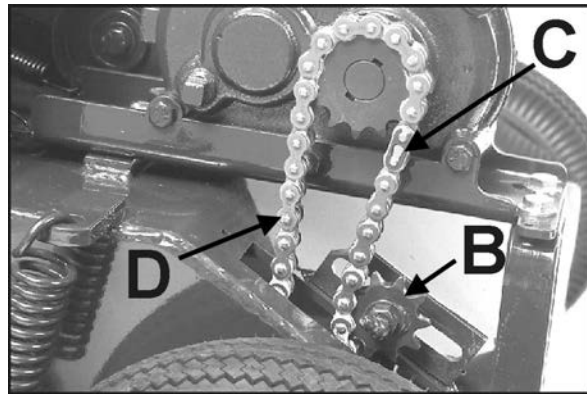

REEL REMOVAL AND INSTALLATION

NOTE: All references to front, rear, right and left are from the perspective of an operator in the operator position.

1. Remove the guards covering the belts and transmission. Tilt the unit forward and support the rear of the chassis with jack stands.

⚠ WARNING

Fire Hazard.
Prevent fuel spillage.
Empty fuel tank before tilting unit forward.

Crush Hazard
Support rear of tilted unit adequately.

2. Remove the lower belt guard from under the chassis by removing the screw at the front of the guard and swinging the guard down.
3. Move the reel clamp levers **E** (left and right side) rearward to release the reel clamps.
4. Lower the left end of the reel and remove the three belts from the pulley at the right end. Remove the reel. If the blades need to be replaced, refer to the section on reel blade replacement.
5. Reinstall the reel in the reverse order of removal.

⚠ CAUTION

A loose reel may cause injury or property damage.
Be certain the reel clamp lever locks over center to keep the reel from working loose.

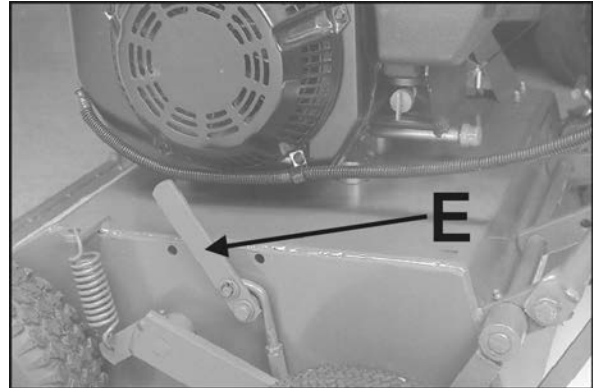

TRANSMISSION GEAR REPLACEMENT

1. Remove the transmission from the unit.
2. Remove the sprocket, pulley and keys.
3. Remove the plug and drain the oil from the gear case.
4. Remove the the remaining hardware. Take note of which side is the input side and which is the output side so that they can be reassembled correctly. Using a soft hammer, tap case on the tabs to break the seal, and pull halves **E** & **F** apart.
5. Remove the input shaft **A**, output shaft **B** and spacer **C**. Also remove the bearings **D** and grease seals.
6. Install new bearings into both case halves.

INPUT SHAFT

7. Remove large double gear **E**, small gear **F**, key **G**, and spacer **H** from input shaft **J**.
8. Check the input shaft for wear and replace if necessary (if shaft needs to be replaced, install the existing snap ring **K** on new shaft). If the shaft is NOT replaced, remove any burrs from keyways and/or shaft ends if necessary.
9. Replace bushings in the large double gear **E** (or replace gear if necessary). When replacing bushings, make sure they are flush with the edge of the gear and that the oil holes on gear are aligned.
10. Install the spacer **H** onto shaft against the snap ring **K**. Install the large double gear **E**, with the small gear side against the spacer.
11. Install key **G** into keyway and slide the small gear **F** (flat side toward the larger gear) onto the shaft.

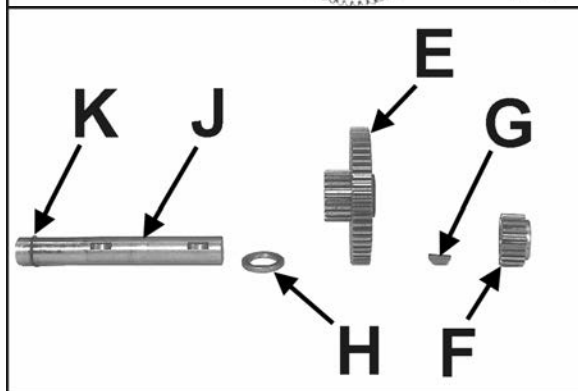
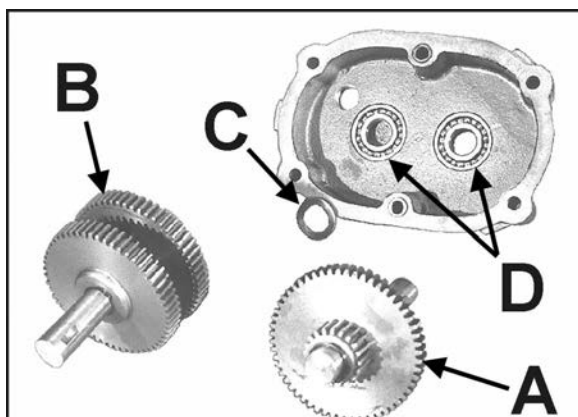
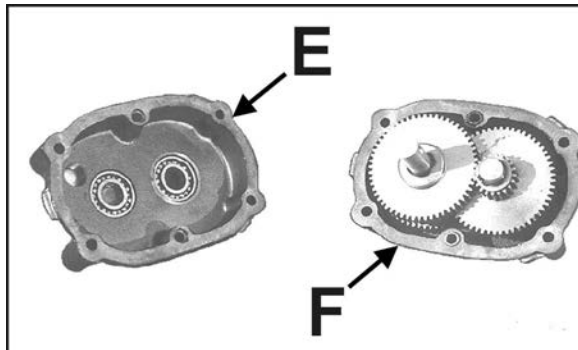

OUTPUT SHAFT

12. Remove large gear **L** , large double gear **M** and key **N** from shaft **P**. Check the shaft for wear and replace if necessary (if shaft needs to be replaced, install the existing snap ring **O** on new shaft). If the shaft is **NOT** replaced, remove any burrs from keyways and/or shaft ends if necessary.
13. Replace bushings on large double gear **M** (or replace gear if necessary). When replacing bushings, keep the bushings flush with the edge of the gear. Be sure oil holes on gear are aligned.
14. Install key **N** and large single gear **L** onto shaft **P** (be sure the deep-step side of gear is toward snap ring **O**).
15. Slide the large double gear **M** onto shaft, with the small gear toward the large single gear.
16. Install spacer onto output shaft.
17. Clean the old gasket material from the case halves.
18. Install the input and output shafts into the gear case half, making sure the spacer on the output shaft remains in place.
19. With shafts in gear case half, turn either shaft to make sure gears are turning. This will ensure the keys are properly set.
20. Apply Loctite 515 sealant (or equivalent) to case halves. Make sure the spacer bushings are in the center top and bottom holes of the case half.

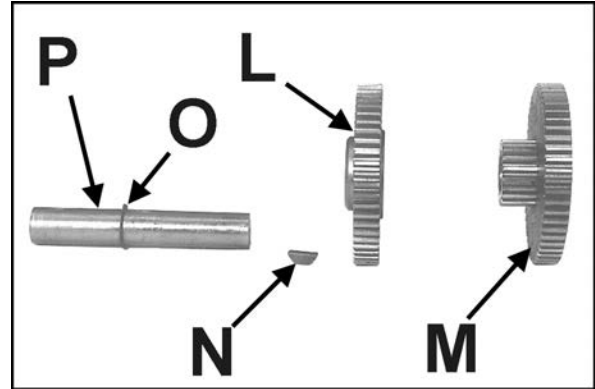

21. Position transmission onto the mounting bracket with the drain plug facing to the outside of unit. Reinstall the six screws removed during disassembly. Secure all six screws and torque to 16 + 2 ft.- lbs. (21.5 N·m).
22. Apply 30w oil onto the lips of the new grease seals. Install the seals, drive pulley, and sprocket.
23. With the gear case resting level on the mounting bracket, fill transmission with EP90w oil until the oil reaches the bottom of the threads in the plug hole. Install plug (use a teflon based thread sealer on the threads). The transmission will hold 1/2 pint (.4L) of oil.
24. Check the alignment of the belt pulley and chain sprocket. If necessary, loosen the set screws securing the pulley and sprocket to the shaft and position each until properly aligned. If alignment cannot be reached refer to the previous instructions for adjustment of belts and chain.

STORAGE INSTRUCTIONS

⚠ WARNING

To prevent possible explosion or ignition of vaporized fuel, do not store equipment with fuel in tank or carburetor in enclosure with open flame (for example, a furnace or water heater pilot light).

Do not smoke, avoid sparks and open flames when draining or filling the fuel tank.

Before the equipment is put in to storage for any period exceeding 30 days, the following steps should be taken.

1. Drain all fuel from the fuel tank and fuel lines.
2. Start the engine and run until all the fuel is used from the carburetor float bowl.
3. While engine is warm, drain the crankcase oil and replace it with the proper weight oil corresponding to the season the unit will next be used. Refer to the engine manual for proper oil recommendations.

⚠ CAUTION

Do not attempt to service or make repairs near the engine area while the engine is still hot.

4. Remove the spark plug and squirt a small amount of clean motor oil into the cylinder. Turn the engine over a few times to distribute the oil and reinstall the sparkplug.
5. Lubricate all lubrication fittings.
6. Apply a light coat of oil to the blades and reel shaft to prevent rust.
7. Lubricate drive chain with Lubriplate brand #13563 or equivalent.

NOTE: Do not store unit with blades in the down position. Be sure all belts are free from tension (the clutch control lever in the disengaged position).

To put the equipment into service after an extended period of storage:

1. Move unit to a level, well ventilated area.
2. Check unit for loose hardware and broken parts. Tighten and replace as necessary.
3. Check for cracked or split fuel lines.
4. Make sure the air cleaner filter is clean.
5. Check that the air cleaner components and all shrouds and belt covers are in place.
6. Check spark plug and plug wire.
7. Note if any blades need replacing.
8. Determine if the transmission and engine oil need filling. Refill engine oil according to the manufacturers recommendations, and refer to the Preventive Maintenance section of this manual for correct oil weight and amount for the transmission.
9. Fill the tank with appropriate fuel as recommended by the engine manual.

⚠ WARNING

Do not smoke, avoid sparks and open flames when draining or filling the fuel tank.

10. Make sure controls are in the disengaged or neutral position.
11. Start engine and let run (at slow speed) until approximate operating temperature has been reached.
12. While engine is running (and has reached operating temperature) visually inspect fuel lines and carburetor for leaks. If a leak is found, make sure the engine has cooled sufficiently before attempting any repairs.

TRANSPORTING

The unit may be transported under its own power. With the lift lever up and the clutch control disengaged, start the engine and compress and hold the operator presence lever. Engage only the drive transmission clutch by pushing the clutch control forward **without** pulling the reel control lever back. Set the throttle to the operator's desired walking speed.

The unit may be loaded into the back of a truck or trailer using a gradual sloped ramp and operating the unit in the same manner as stated previously.



WARNING

Use adequate lifting device and/or assistance when loading and unloading unit. If loading by ramp, be sure ramp is properly supported.

Keep hands and feet from underneath the unit while operating or ramp loading the unit.

SPECIFICATIONS

MATAWAY OVERSEEDER

SPECIFICATIONS	
Front axle 3/4" (19 mm) diameter mounted in self-aligning ball bearings	Drive"A" section belt from engine to gear box No. 40 roller chain from gearbox to front axle Matched set of 3, V section belts from engine to reel
Rear axle 3/4" (19 mm) diameter welded to pivot arms	EngineModel No. GX390UT2, 11.7 H.P. Honda Governor set at 3200 r.p.m. (no load). Engine displacement: 23.7 cu. in. (389 cc) and develops 18.5 ft.-lbs. (25.1 N·m) of torque at 2500 r.p.m.
BladesHigh carbon steel (hardened)	Seed Hopper Capacity0.83 cu. ft. (0.0235 cu. m)
Chassis3/16" (5 mm) formed and welded steel plate	ReductionEngine to reel - 1:1 Engine to wheels - 37.3:1
ClutchBelt tightener type for reel and forward travel	ReelQuick change mounting Rotation in opposite direction of forward motion
ControlsThrottle control, lift lever combined drive and reel clutch lever	Seed DensityAdjustable for seed type
Depth AdjustmentMicrometer screw	Seed Flow Controlseed dispensed automatically when unit is lowered, stops when reel is raised.
Depth of CutUp to 1/4" (6 mm)	Seed Spacingseed rows 2" (50mm) apart
Dimensions:	Reel Speed3200 r.p.m.
Width36" (91cm)	WheelsFront; 4.10/3.50 - 4, pneumatic tires chain driven Rear; 4.10/3.50 - 4 pneumatic tires free wheeling on self-aligning ball bearings.
Height44" (112cm) including handle	
Length53" (135cm) including handle	
Wheelbase16 1/2" (42cm)	
Width of cut19" (483 mm)	
Net Weight425 lbs. (195 Kg) with 547553 Reel	
Gear Case22 to 1 reduction	
Speed ...214 ft./min.(65m/min.) at 3200 engine r.p.m.	

PARTS SECTION

CHASSIS

MATAWAY OVERSEEDER

FIGURE 1

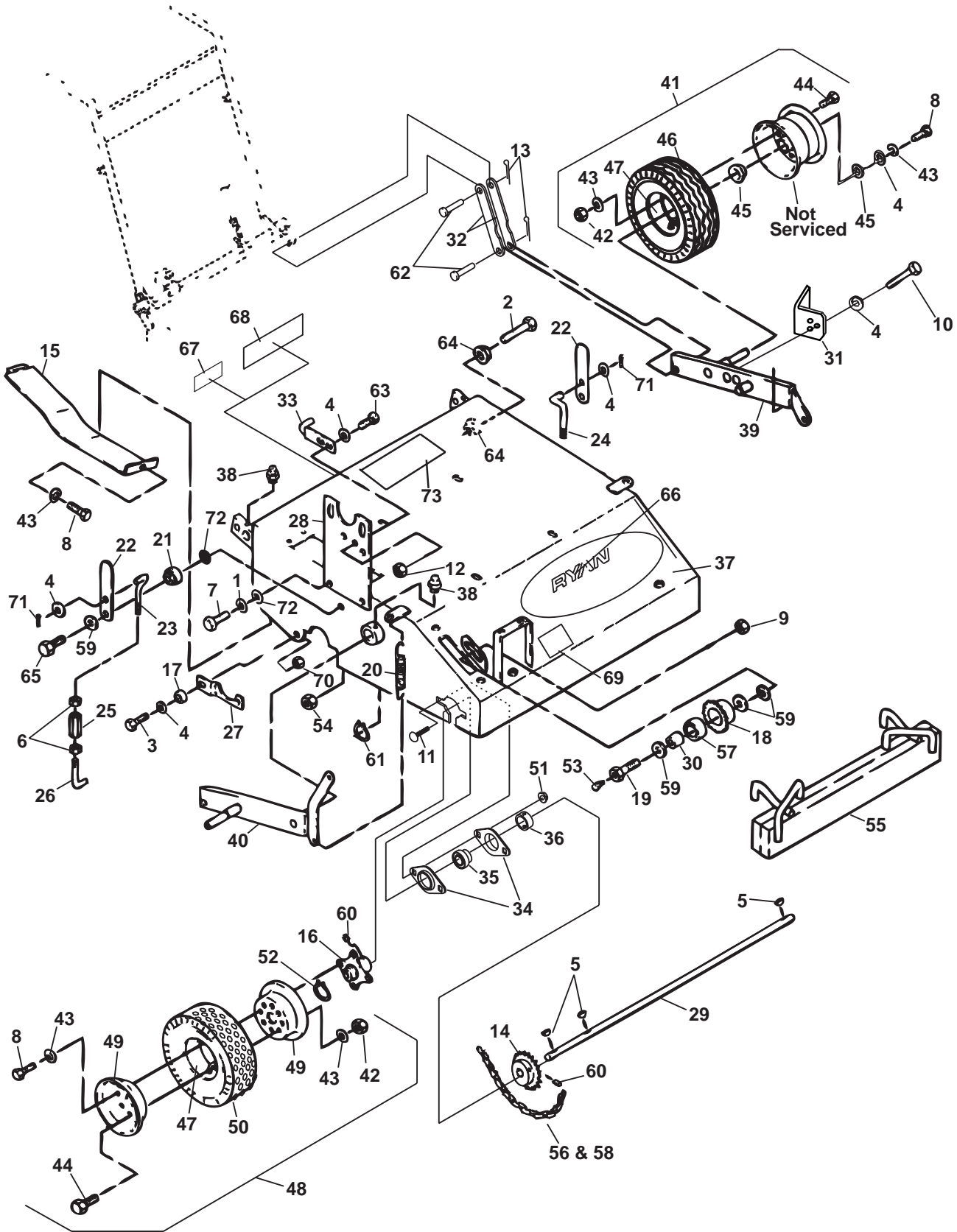

MATAWAY OVERSEEDER

CHASSIS

FIGURE 1

ITEM	PART NO.	DESCRIPTION	QTY	ITEM	PART NO.	DESCRIPTION	QTY
1	64006-03	WASHER, 3/8 HELICAL LCK	2	49	517332	RIM	1
2	64123-82	BOLT-HEX 3/8-16X2-1/2	1	50	523264	TIRE	1
3	64123-107	BLT-HEX 5/16-18X7/8	2	51	64141-6	NUT, 5/16-18	4
4	64163-55	WASHER .328X.75X14 GA	12	52	64144-02	SNAP RING 3/4	2
5	64164-19	KEY WOODRUFF.19X.75 #9	3	53	29-045	GREASE FTG 1/4-28 45DEG	1
6	64001-2	NUT-JAM 3/8-16	4	54	64151-18	NUT, HEX	2
7	64123-50	BOLT-HEX 3/8-16X1	2	55	4163603.7	WEIGHT AY	1
8	64123-54	BLT-HEX 5/16-18X3/4	11	56	4163735	CHAIN,#40 ROLLER	1
9	64268-03	NUT-3/8-16 HEX	1	57	521845	BEARING,NEEDLE	1
10	64197-001	BLT-TDFM 5/16-18X3/4	4	58	4113841	CONNECTOR LINK #40 NP	1
11	64018-9	BLT-CRG 5/16-18X3/4 G5	4	59	64163-61	WSHR .81X.406X16GA	5
12	64268-02	NUT-FL NYLN LCK 5/16-18	2	60	644044-18	SCREW-SET 5/16-18 x 5/16	6
13	64140-1	COTTER PIN	4	61	64144-03	SNAP RING 7/8"	2
14	841261	SPROCKET, 16T 1/2P BLK	1	62	64188-36	PIN CLEVIS 7/16X1-1/4	4
15	516825.7	GUARD	1	63	64123-68	BLT-HEX 5/16-18X1	2
16	516944	HUB	2	64	64141-4	NUT-WLF 3/8-16	2
17	517226	BRG,SLV .33 .50 .20 IRON	2	65	64123-87	BOLT-HEX 3/8-16X1-3/4	2
18	517348	SPROCKET	1	66	4161123	LABEL-RYAN OVAL LARGE	1
19	517641	SCRW,SPCL.38-16 1.75 HX	1	67	524544	DECAL,REEL HEIGHT ADJ.	1
20	518506	SPRING	2	68	4163696	DECAL,DANGER	1
21	519038	BUSHING	2	69	4163592	LABEL-BELTS/SERVICE	1
22	4163618.7	LEVER	2	70	64229-02	NUT-NYLOC 5/16-18	2
23	519040	HOOK, UPPER RIGHT	1	71	64168-2	COTTER-HAIRPIN .08x1.19	2
24	519041	HOOK, UPPER LEFT	1	72	64163-31	WSHR-25-64X1X12	4
25	519042	NUT	2	73	340830	DECAL-CAUTION SPANISH	1
26	4130674	CLAMP, ROD LOWER	2				
27	4163522.7	CLAMP, REEL	2				
28	4163619.7	PLATE	1				
29	519059	SHAFT,FRONT	1				
30	519874	RACE,INNER	1				
31	4163635.7	SCRAPER, WHEEL	2				
32	4163630.7	LINK, LIFT	4				
33	4163602.7	STOP, BELT	1				
34	548962	HOUSING,BEARING	4				
35	521856	BEARING,BALL	2				
36	521857	COLLAR,BRG LOCKING	2				
37	540195	S-FRAME W/ DECALS	1				
38	85010N	FITTING,GREASE 1/4 SPC	4				
39	4163614.7	ARM, LEFT	1				
40	4163613.7	ARM, RIGHT	1				
41	4124194	WHEEL, 4.10/3.50-4 2PLY INCLUDES ITEMS 42-47)	2				
42	64025-03	NUT-HEX 5/16-24	4				
43	64006-02	LOCKWSHR-HELICAL 5/16	15				
44	306861	SCRW,.31-24.625 YS HX	4				
45	548123	BEARING, WHEEL	2				
46	548543	TIRE-4.10/3.50-4, 2 PLY	1				
47	548546	TUBE	1				
48	4124196	WHEEL ASSY (INCLUDES ITEMS 42-44, 47, 49 & 50)	2				

HANDLE ASSEMBLY

MATAWAY OVERSEEDER

FIGURE 2

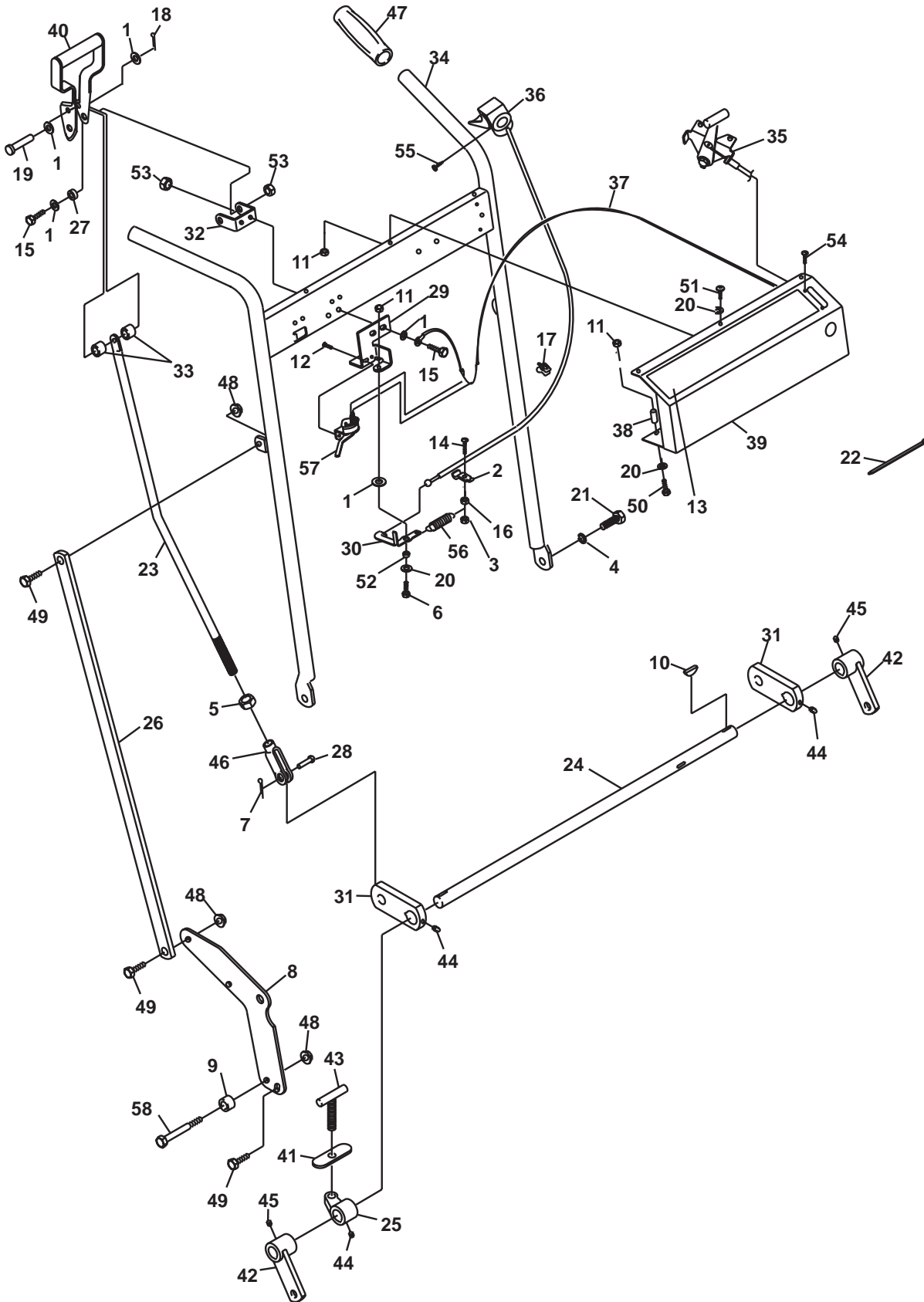

MATAWAY OVERSEEDER

HANDLE ASSEMBLY

FIGURE 2

ITEM	PART NO.	DESCRIPTION	QTY	ITEM	PART NO.	DESCRIPTION	QTY
1	64163-55	WASHER .328X.75X14 GA	7	52	814585	BUSHING	1
2	111898	CLAMP,CABLE	1	53	64268-02	NUT-FL NYLOC 5/16-18	4
3	64229-10	NUT-NYLON LOCK 10-24	1	54	64152-18	SCR 8-32 X 3/8 S-TAP	2
4	64006-05	LOCKWSHR-HELICAL 1/2	2	55	64197-023	BLT-TDFM 10-32 X 3/4	1
5	64001-10	NUT-HEX JAM 7/16-20	1	56	805421	SPRING,EXTENSION	1
6	64123-89	BOLT-HEX 1/4-20X3/4	1	57	806800	SWITCH,STOP LIGHT	1
7	64140-1	COTTER PIN-1/8X1	1	58	64123-67	BOLT-3/8-16X2 HEX	2
8	4163631.7	PLATE, MOUNTING	2				
9	522683	BUSHING, PIVOT	2				
10	64164-19	KEY WOODRUFF.19X.75 #9	5				
11	64229-01	NUT-NYLOON LOCK 1/4-20	5				
12	64197-015	BLT-TDFM 10-32X1/2 TRXHD2					
13	4167491	DECAL,CONTROL PANEL	1				
14	64189-18	BLT-HEX SOC 10-24X3/4 LG	1				
15	64123-68	BOLT-HEX 5/16-18X1	4				
16	64025-15	NUT-HEX #10-24 KEPS	2				
17	813840	CLIP	1				
18	64140-1	COTTER PIN-3/32X1/2	1				
19	64188-62	PIN CLEVIS 5/16X2.25	1				
20	64163-03	WSHR-.256X.62X18GA.	5				
21	64123-73	BLT-HEX 1/2-13X1	2				
22	65286-4A	TIE,CABLE 11-5/8 BLACK	2				
23	515838.7	ROD, CONTROL	1				
24	516855	SHAFT	1				
25	516859.7	LEVER, ADJUSTING	1				
26	4163626.7	BRACE	2				
27	521679	BUSHING	2				
28	64188-36	PIN,CLEVIS 7/16X1-1/4	1				
29	524490	MOUNT,SWITCH (PLATED)	1				
30	524493	ARM,PIVOT	1				
31	524513.7	ARM, LIFT	2				
32	524526.7	BRACKET, LIFT HANDLE	1				
33	524578	BUSHING, .328X.63X.6	2				
34	4164131	HANDLE AY	1				
35	540243	CONTROL AY,THROTTLE	1				
36	540245	CONTROL AY,KILL SWITCH	1				
37	540229	WIRE AY, 7.5"	1				
38	820529	SPACER (PLATING)	1				
39	4167494	COVER, CNTRL W/DECALS	1				
40	4163585.7	HANDLE AY	1				
41	4163617	HANDLE AY,LOCKING PLTD	1				
42	4163599.7	ARM AY,FRAME LIFT	2				
43	4163604	SCREW AY, ADJUST PLTD	1				
44	64044-18	SETSCREW, 5/16-18 X 5/16	3				
45	64044-3	SSCRW-3/8-16 X 5/16	2				
46	548507	CLEVIS	1				
47	4163734	HAND GRIP	2				
48	64268-03	NUTFL NYLON LOCK 3/8-16	6				
49	64139-24	BLT-WLF 3/8-16 X 1	6				
50	64123-07	BLT-HEX 1/4-20X1-1/2	1				
51	64123-89	BLT-HEX 1/4-20X3/4	3				

CLUTCH ASSEMBLY AND CONTROL

MATAWAY OVERSEEDER

FIGURE 3

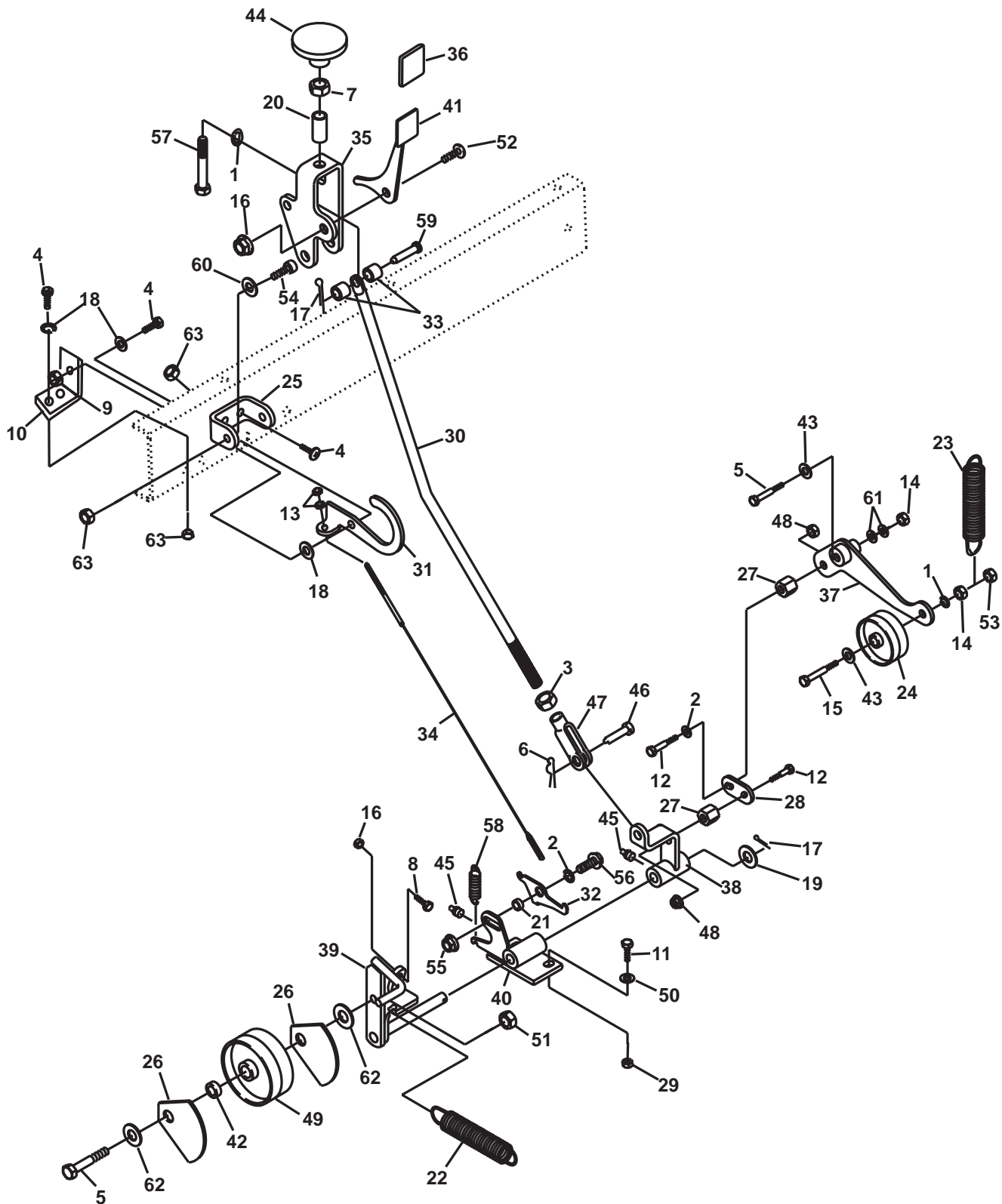

MATAWAY OVERSEEDER

CLUTCH ASSEMBLY AND CONTROL

FIGURE 3

ITEM	PART NO.	DESCRIPTION	QTY	ITEM	PART NO.	DESCRIPTION	QTY
1	64006-03	WASHER, 3/8 HELICAL LCK	2	51	64268-03	NUT-FL NYLON LOCK 3/8-16	1
2	64163-55	WASHER .328X.75X14 GA	2	52	64218-06	SCR-BTN HD 5/16-18X3/4	1
3	64001-10	NUT-HEX JAM 7/16-20	1	53	64151-18	NUT, HEX	1
4	64123-89	BOLT-HEX 1/4-20X3/4	5	54	64189-3A	BLT-HEX SOC 1/4-20X5/8	2
5	64123-82	BOLT-HEX 3/8-16X2-1/2	2	55	64268-02	NUT-FL NYLON LCK 5/16-18	1
6	64168-2	COTTER-HAIRPIN.08X1.19	1	56	64262-006	BLT-FLG HD 5/16-18 X 3/4	1
7	64025-04	NUT-3/8-24 HEX	1	57	64123-270	BLT-HEX 3/8-24X2-1/4	1
8	64123-107	BLT-HEX 5/16-18X7/8	1	58	805421	SPRING,EXTENSION	1
9	64025-01	NUT-1/4-20 HEX	1	59	64188-63	PIN-CLEVIS, 5/16 X 1.75	1
10	4163596.7	BRACKET-CAM CONTROL	1	60	64163-86	WSHR-FLAT.265X.625X.125	2
11	64123-50	BOLT-HEX 3/8-16X1	2	61	64163-46	WSHR-.383/.393x.88 7GA	2
12	64123-69	BOLT-5/16-18X1-1/2 HEX	2	62	64163-04	WSHR-25-64X5/8X16GA	2
13	64025-15	NUT-HEX #10-24 KEPS	2	63	64229-01	NUT-NYLOCK 1/4-20	5
14	64025-05	NUT-3/8-16 HEX	2				
15	64123-100	BOLT-3/8-16X2-1/4 HEX	1				
16	64025-02	NUT-HEX 5/16-18	2				
17	64140-1	COTTER PIN-1/8X1	2				
18	64163-03	WSHR-.256X.62X18GA.	4				
19	64163-67	WASHER-.516X1X12GA	1				
20	516544	BUSHING (PLATING)	1				
21	517226	BRG,SLV .33 .50 .20 IRON	1				
22	2701258	SPRING, TSN 1.0X3.62X14	1				
23	518487	SPRING	1				
24	522882	PULLEY,IDLER	1				
25	4163620.7	BRACKET, HANDLE	1				
26	4163627.7	GUIDE, BELT	2				
27	524507	NUT,SSPCL.312-18 Z HX	2				
28	4166562	LINK (PLATING)	1				
29	64229-03	NUT-NYLOCK 3/8-16	2				
30	524561.7	ROD, CONTROL	1				
31	4163633	CAM,CONTROL (PLATED)	1				
32	4163634	TRIGGER,LOCKING PLTD	1				
33	524577	BUSHING,.328X.63X.41	2				
34	524579	CABLE,CONTROL	1				
35	524585.7	HANDLE, CONTROL	1				
36	4163745	COVER,VINYL	1				
37	4163612.7	ARM AY	1				
38	4163611.7	PIVOT	1				
39	4163610.7	IDLER ARM	1				
40	4163609.7	BRACKET	1				
41	4163730	LEVER AY,CONTROL PLTD	1				
42	822474	SPACER	1				
43	64163-61	WSHR .81X.406X16GA	2				
44	548171	KNOB	1				
45	29-045	FITTING,GREASE 1/4	2				
46	64188-36	PIN,CLEVIS 7/16X1-1/4	1				
47	548507	CLEVIS	1				
48	64141-6	NUT, 5/16-18	2				
49	548942	PULLEY, PLAIN FLAT 3.25	1				
50	64163-31	WSHR 25/64X1X12	2				

ENGINE AND DRIVE ASSEMBLY

MATAWAY OVERSEEDER

FIGURE 4

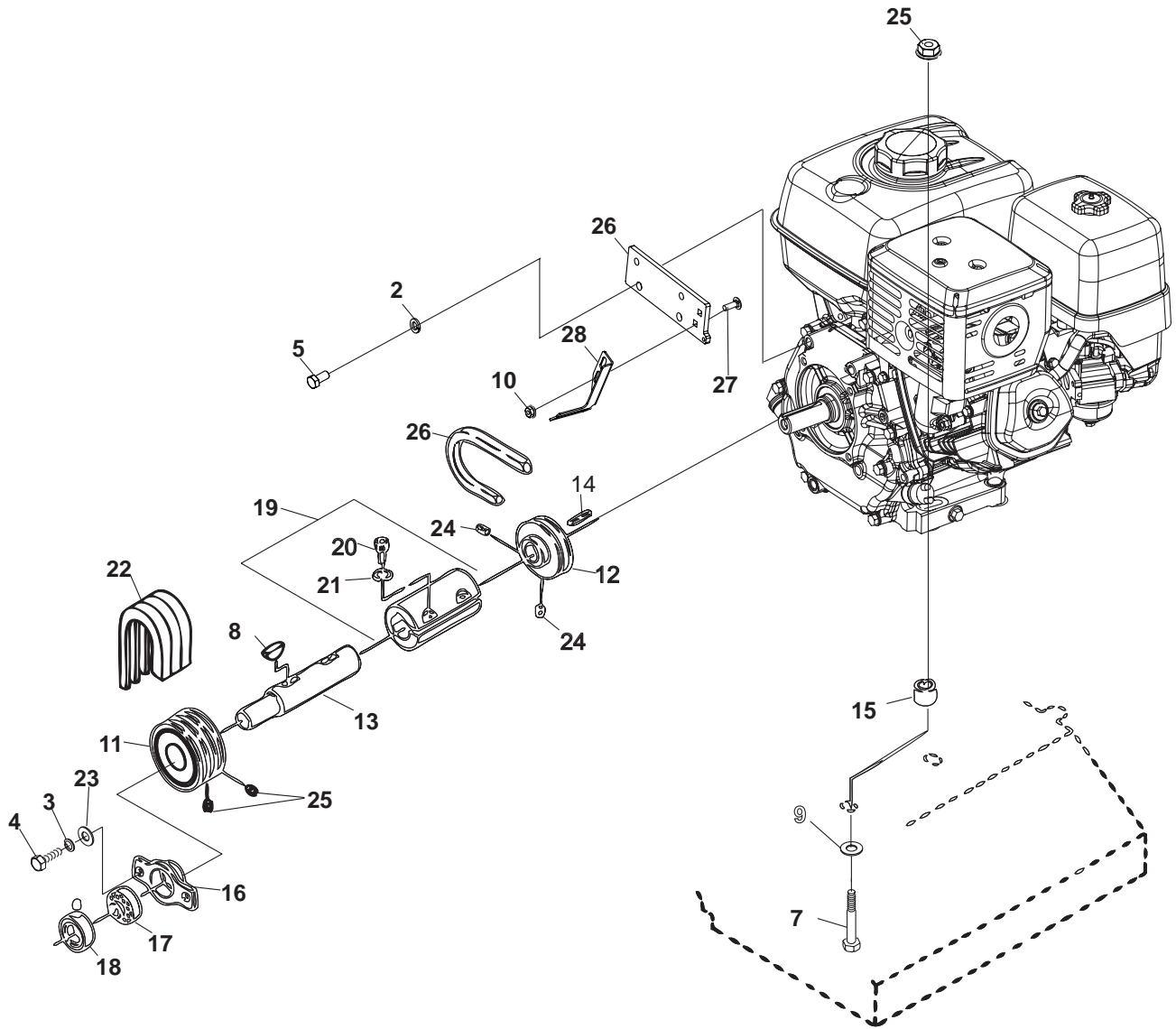

MATAWAY OVERSEEDER

ENGINE AND DRIVE ASSEMBLY

FIGURE 4

ITEM	PART NO.	DESCRIPTION	QTY	ITEM	PART NO.	DESCRIPTION	QTY
1	64044-3	SCRW-SET3/8-16X5-16	2				
2	64006-03	LCKWSHR-3/8 HEL	2				
3	64006-03	WSHR, 3/8 HELICAL LCK	2				
4	64123-50	BOLT-HEX 3/8-16X1	2				
5	64123-15	BLT-CRG 1/4-20 X 3/4	2				
6	548403	V-BELT	1				
7	64123-75	BOLT-3/8-16X3 HEX	4				
8	64164-25	KEY-1/4X7/8 #807	2				
9	64163-82	WASHR,.39 1.25.19 FLAT	4				
10	64268-01	NUT-FL NYLOCK 1/4-20	2				
11	516892	PULLEY, REEL BELT	1				
12	517101	PULLEY,3 IN. DIA BLK	1				
13	517123	SHAFT	1				
14	64164-13	KEY,.25 X2 SQ	1				
15	838790	SPACER, ENG MNT PLTD	4				
16	519809	PILLOW BLOCK	1				
17	521856	BEARING,BALL	1				
18	521857	COLLAR,BRG LOCKING	1				
19	547755	COUPLING	1				
		(INCLUDES ITEMS 20 & 21)					
20	64189-15	SCRW,.31-18 1.00 BS HS	2				
21	64006-16	LWSHR,.31.09 HI-COLLAR	2				
22	547759	BELT,DRIVE, SET OF 3	1				
23	64163-31	WSHR 25/64X1X12	2				
24	64044-18	SETSCREW, 5/16-18 X 5/16	2				
25	64268-03	NUT-FL NYLOCK 3/8-16	4				
26	4166458.7	PLTAE-ENGINE MOUNT	1				
27	64018-2	BLT-CRG 1/4-20 X 3/4	2				
28	4166459.7	GUIDE-BELT ADJ	1				

TRANSMISSION

MATAWAY OVERSEEDER

FIGURE 5

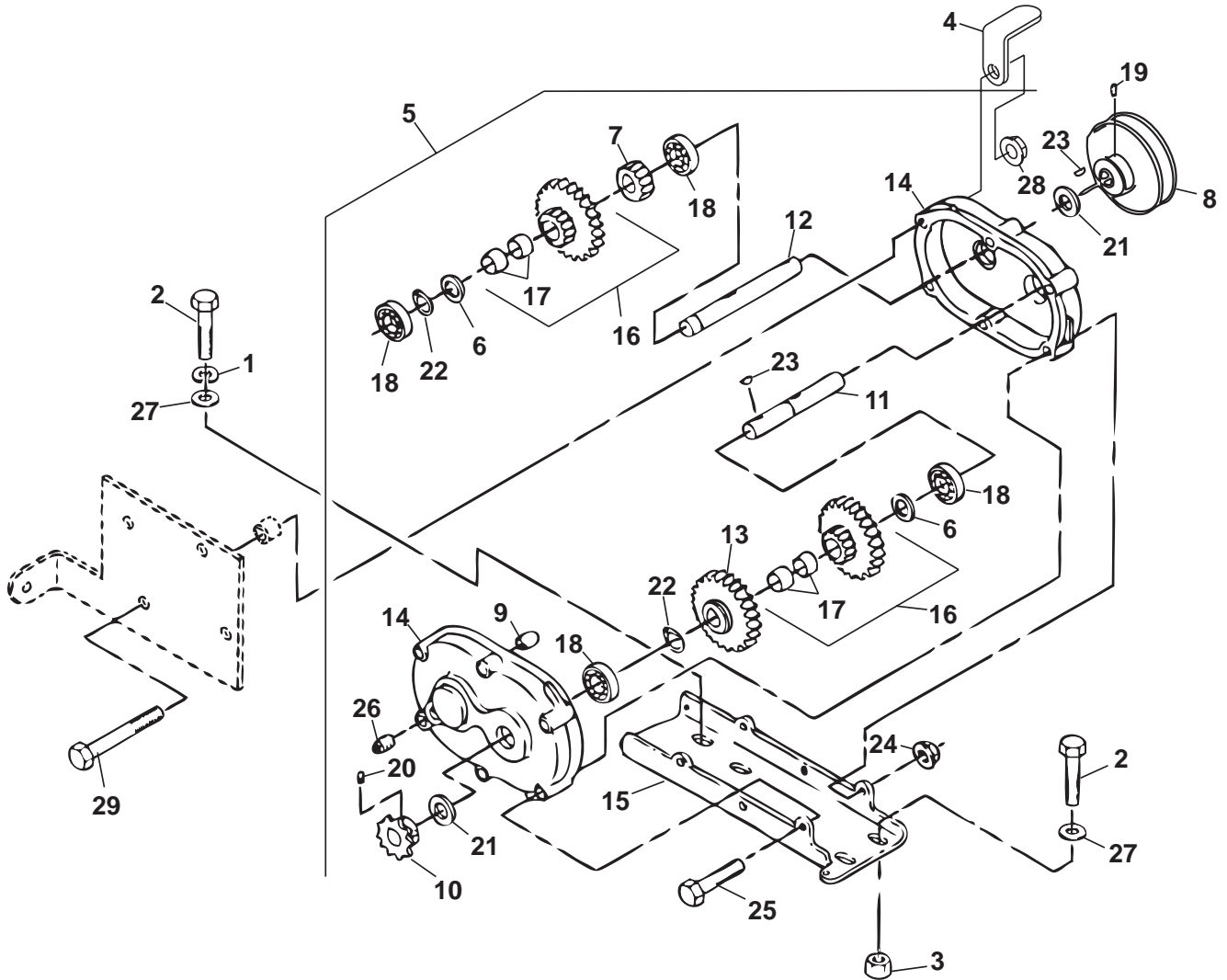

MATAWAY OVERSEEDER

TRANSMISSION

FIGURE 5

ITEM	PART NO.	DESCRIPTION	QTY	ITEM	PART NO.	DESCRIPTION	QTY
1	64006-03	WASHER, 3/8 HELICAL LCK	2				
2	64123-50	BOLT-HEX 3/8-16X1	4				
3	64268-03	NUT-3/8-16 HEX	2				
4	4163641	GUIDE,BELT (PLATING)	1				
5	4163650	TRANSMISSION AY	1				
(INCLUDES ITEMS 6,7,9,11-14, 16-18, 21-26 ONLY 2 INNER KEYS ITEM 23 SUPPLIED)							
6	516700	SPACER	2				
7	516724	GEAR	1				
8	517137	PULLEY,4" DIA "A" SIZE	1				
9	517226	BRG,SLV .33 .50 .20 IRON	2				
10	517342	SPROCKET	1				
11	518820	SHAFT, OUTPUT	1				
12	518826	SHAFT, INPUT	1				
13	518827	GEAR	1				
14	522638	CASE, GEAR	2				
15	4163628.7	BRACKET, MOUNTING	1				
16	2702142	GEAR AY,IDLER 56T/20T (INCLUDES ITEM 17)	2				
17	515511	BUSHING	2				
18	548119	BRG,BALL.75 1.62.31 "OP"	4				
19	64044-18	SCREW,SET 5/16-18 x 5/16	2				
20	85-SS14	SSCRW,3/8-16 X 3/8 SKTHD	1				
21	548274	OIL SEAL	2				
22	64144-02	SNAP RING 3/4	2				
23	64164-37	KEY, WDRUF 5/16X5/8 #605	4				
24	64141-6	NUT-WLF 5/16-18	6				
25	64123-66	BLT-HEX 5/16-18X3-1/2	6				
26	69051-01	PLUG-PIPE 3/8	2				
27	64163-31	21	4				
28	64268-02	NUT-FL NYLON LOCK 5/16-18	1				
29	64123-180	BLT-HEX 5/16-18X4-1/2 (ITEM 5 INCLUDES A QUANTITY OF (6) ITEM 25 (2) OF THESE SCREWS WILL BE REPLACED BY ITEM 29)	2				

GUARDS

MATAWAY OVERSEEDER

FIGURE 6

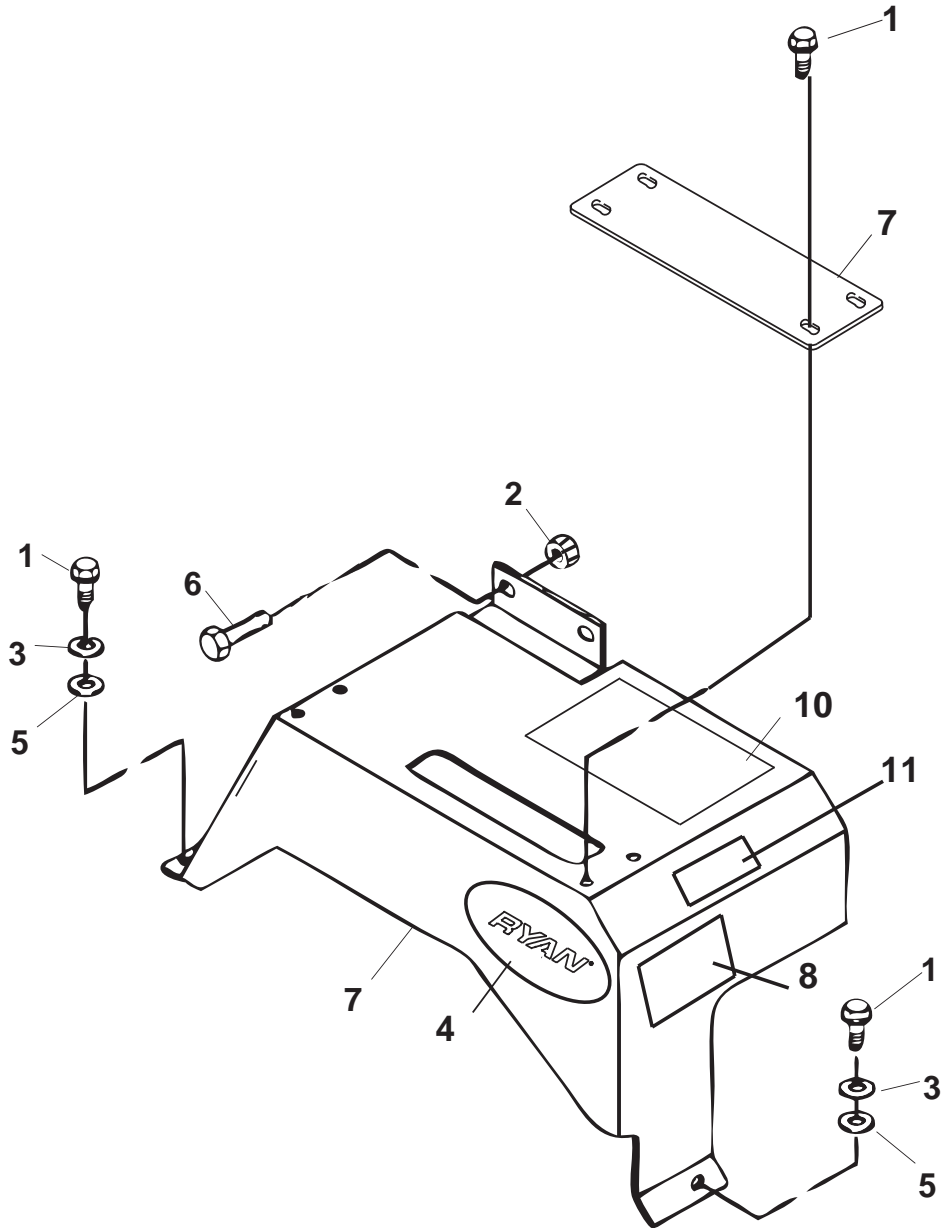

MATAWAY OVERSEEDER

GUARDS

FIGURE 6

ITEM	PART NO.	DESCRIPTION	QTY	ITEM	PART NO.	DESCRIPTION	QTY
1	64197-002	BLT-TDFM 1/4-20X3/4	7				
2	64268-02	NUT-FL NYLOCK 5/16-18	2				
3	64006-01	LCKWSHER-1/4 HELICAL	3				
4	4161123	LABEL-RYAN OVAL, LARGE	1				
5	64163-03	WSHR-.256X.62X18GA.	3				
6	64139-08	BLT-WLF 5/16-18X3/4	2				
7	4166806	S-COVER, BELT	1				
8	4163592	DECAL,WARNING HANDS	1				
9	4163773.2	SHIELD-HOPPER DRIVE	1				
10	524568	DECAL,OP INST	1				
11	4116761	DECAL-MADE IN USA	1				

HOPPER DRIVE

MATAWAY OVERSEEDER

FIGURE 7

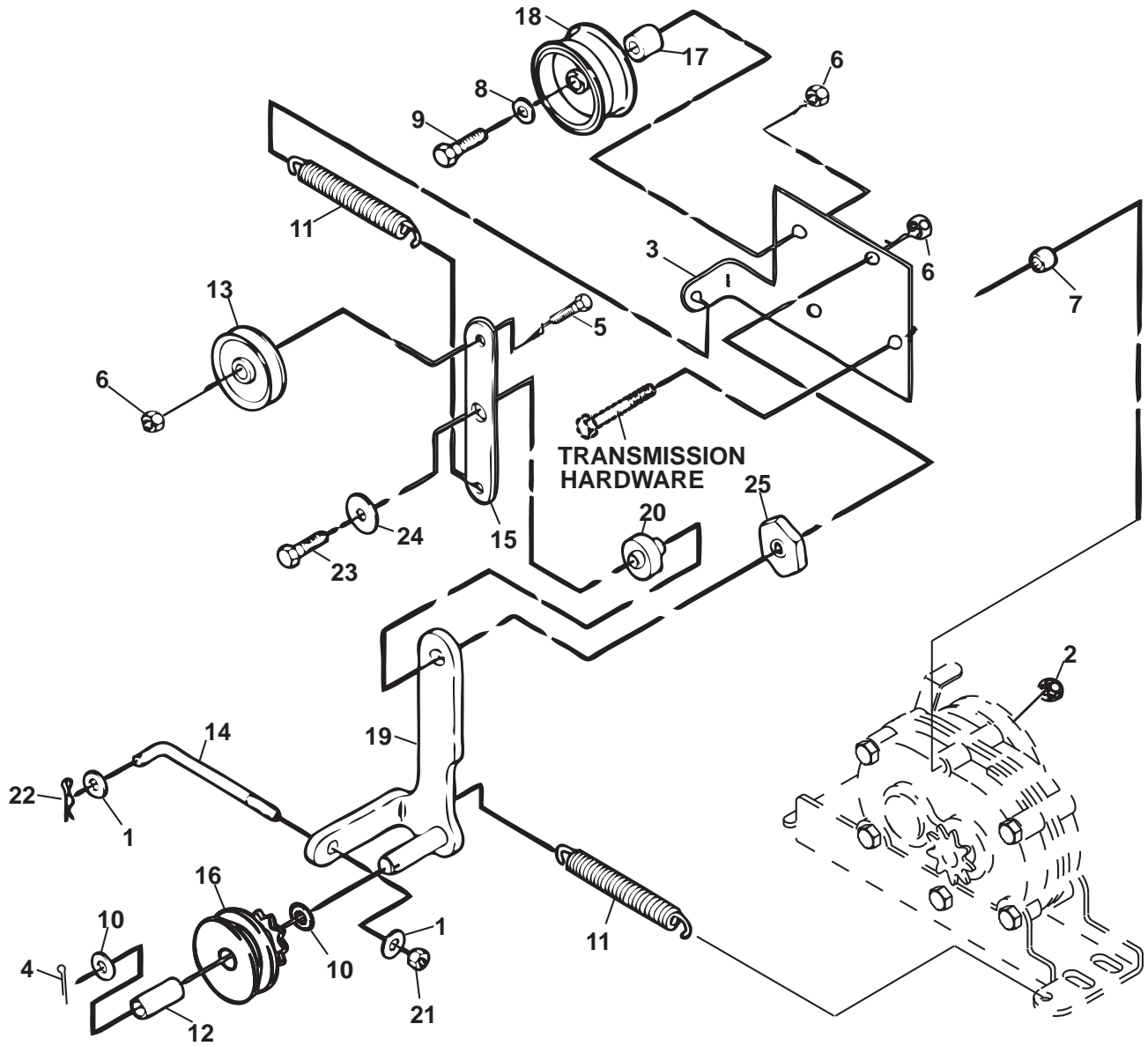

MATAWAY OVERSEEDER

HOPPER DRIVE

FIGURE 7

ITEM	PART NO.	DESCRIPTION	QTY	ITEM	PART NO.	DESCRIPTION	QTY
1	64163-55	WASHER .328X.75X14 GA	2				
2	64268-02	NUT-FL LOCK 5/16-18	1				
3	4163625.7	BRACKET	1				
4	64140-3	COTTER PIN-3/32X3/4	1				
5	64123-87	BOLT-HEX 3/8-16X1-3/4	1				
6	64268-03	NUT-FL NYLON LOCK 3/8-16	3				
7	822474	SPACER	2				
8	64163-61	WSHR .81X.406X16GA	1				
9	64123-75	BOLT, 3/8-16X3 HEX	1				
10	64163-67	WASHER-.516X1X12GA	2				
11	518487	SPRING	2				
12	521031	BUSHING	1				
13	521032	IDLER	1				
14	522606	ROD - CONTROL (PLATING)	1				
15	4163621.7	ARM, IDLER	1				
16	522614	PULLEY, SPROCKET	1				
17	522653	BUSHING	1				
18	522882	PULLEY, IDLER	1				
19	4163601.7	BRACKET, SPROCKET	1				
20	523517	BUSHING	1				
21	64151-15	5/16-18 HEX NUT CNTRLCK	1				
22	64168-2	PIN, HAIR COTTER	1				
23	64123-100	BOLT-3/8-16X2-1/4 HEX	1				
24	64163-82	WASHR, .39 1.25.19 YS FLAT	1				
25	523516	NUT, SPECIAL	1				

HOPPER FRAME

MATAWAY OVERSEEDER

FIGURE 8

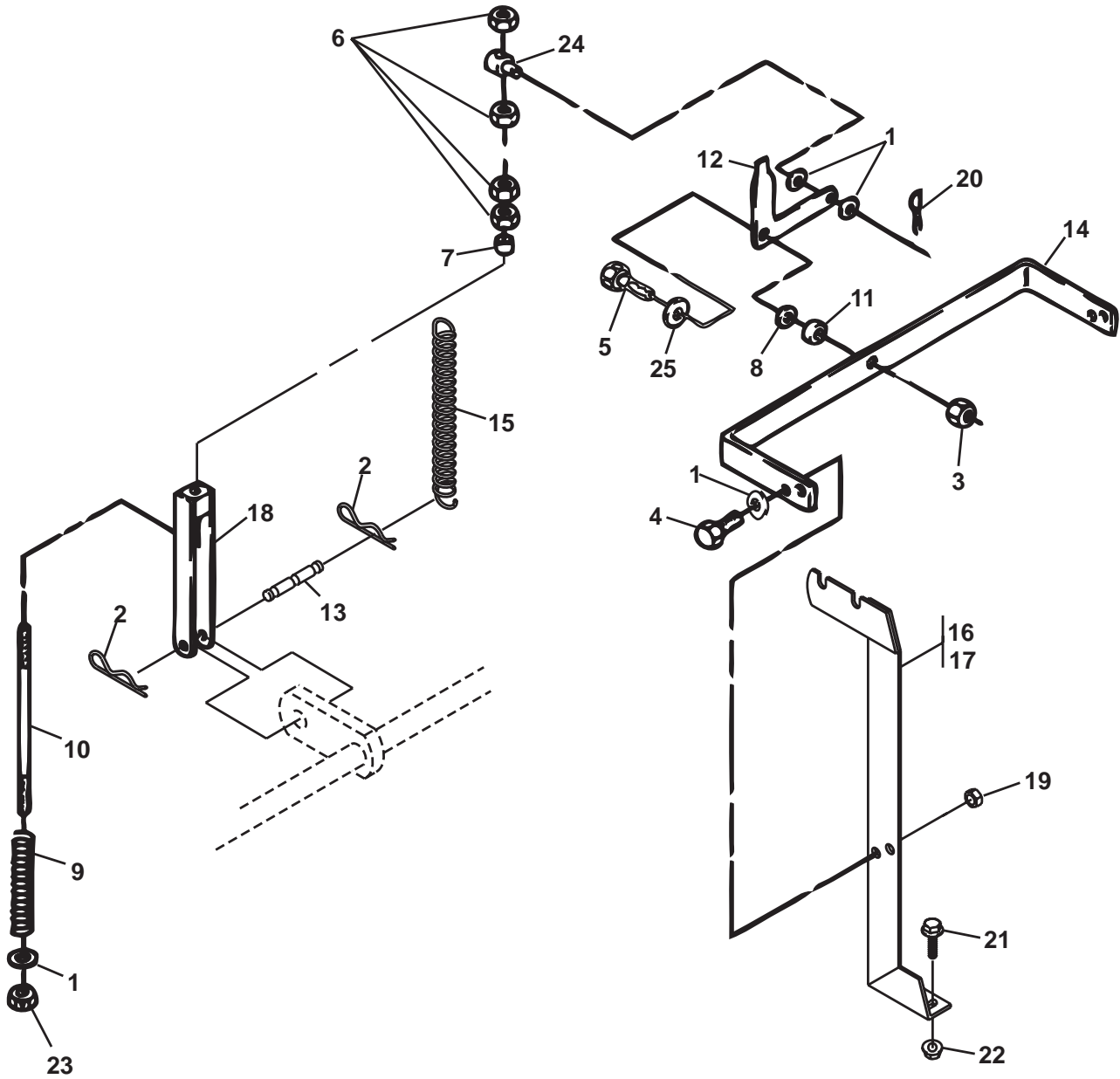

MATAWAY OVERSEEDER

HOPPER FRAME

FIGURE 8

ITEM	PART NO.	DESCRIPTION	QTY	ITEM	PART NO.	DESCRIPTION	QTY
1	64163-55	WASHER .328X.75X14 GA	7				
2	64168-1	COTTER-HAIRPIN.120X2-3/8	2				
3	64268-02	NUT-FL NYLON LOCK 5/16-18	1				
4	64123-68	BOLT-HEX 5/16-18X1	4				
5	64123-61	BLT-HEX 5/16-18X1-3/4	1				
6	64025-02	NUT-HEX 5/16-18	4				
7	516544	BUSHING (PLATING)	1				
8	517226	BRG,SLV .33 .50 .20 IRON	1				
9	522634	SPRING	1				
10	522656	STUD (PLATED)	1				
11	522657	BUSHING (PLATING)	1				
12	4163622.7	LEVER,CONTROL	1				
13	524569	PIN (PLATED)	1				
14	4163574.7	SUPPORT,ARM PIVOT	1				
15	524514	SPRING, EX 1.14X6.64x21	1				
16	4163575.7	SUPPORT, HOPPER LH	1				
17	4163576.7	SUPPORT, HOPPER RH	1				
18	4163606.7	YOKE AY, CONTROL	1				
19	64229-02	NUT-NYLOC 5/16-18	4				
20	64168-2	COTTER-HAIRPIN.08X1.19	1				
21	64139-08	BLT-WLF 5/16-18X3/4	4				
22	64141-6	NUT, 5/16-18	4				
23	64151-15	5/16-18 HEX NUT CNTRLCK	1				
24	806725	PIN,ROD CONNECTING	1				
25	64163-29	WASHER-21/64 X 1 X 11GA	1				

HOPPER AND DISC ASSEMBLY

MATAWAY OVERSEEDER

FIGURE 9

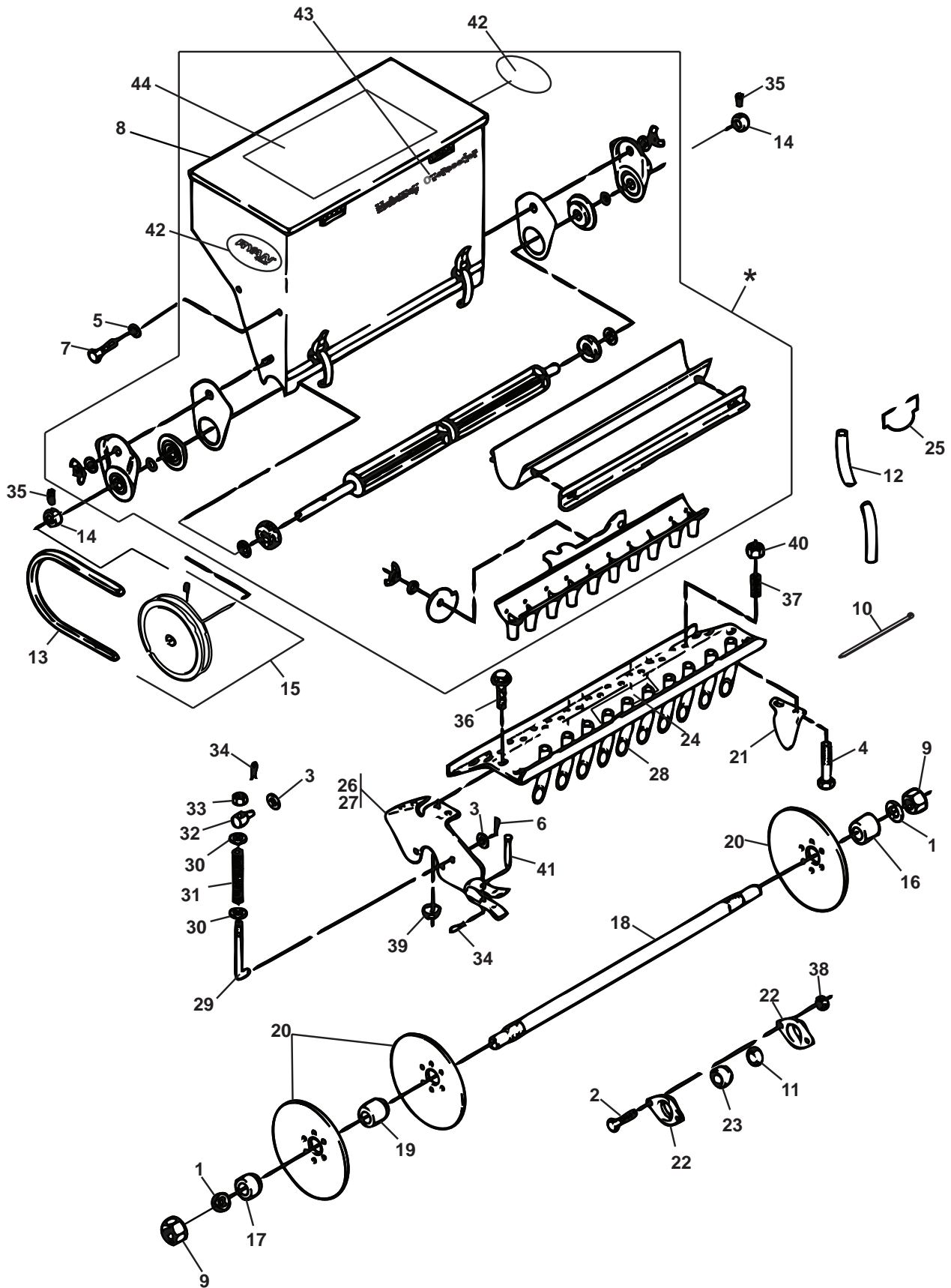

MATAWAY OVERSEEDER

HOPPER AND DISC ASSEMBLY

FIGURE 9

ITEM	PART NO.	DESCRIPTION	QTY	ITEM	PART NO.	DESCRIPTION	QTY
1	95-12	WASHER, .75 1.50.13 FLAT	2	* FOR HOPPER PARTS OR DEALER INFORMATION CONTACT: GANDY CO. 528 GANDRUD ROAD OWATONA, MN USA 550060 REFER TO THEIR MODEL NUMBER 09086877			
2	64018-2	TSCRW,.25-20.62 YS HW	4				
3	64163-61	WASHER .328X.75X14 GA	4				
4	64123-07	BOLT, 1/4-20X1-1/2 HEX	20				
5	64163-29	WSHER-5/16X1	4				
6	64140-3	COTTER PIN-3/32X3/4	2				
7	64123-68	BOLT-HEX 5/16-18X1	4				
8	340830	DECAL-CAUTION SPANISH	1				
9	64001-16	NUT-HEX JAM 3/4-16	2				
10	65286-4A	TIE,CABLE 11-5/8 BLACK	2				
11	522607	COLLAR,LOCKING	2				
12	522632	TUBE	10				
13	522633	V-BELT	1				
14	522652	COLLAR (PLATING)	2				
15	522662	PULLEY,6.50 DIA.	1				
16	522678	SPACER,DISC END, LEFT	1				
17	522679	SPACER,DISC END, RIGHT	1				
18	522680	SHAFT,DISC	1				
19	522682	SPACER,DISC	9				
20	522684	DISC,BLADE	10				
21	4163642	BLADE,SCRAPER PLATED	10				
22	522689	FLANGETTE,TWO BOLT	4				
23	522690	BEARING	2				
24	4163696	DECAL,	1				
25	523493	CLIP,HOSE	10				
26	4163607.2	SUPPORT AY	1				
27	4163600.2	SUPPORT AY,END LH	1				
28	545990	PANEL, TUBE HOLDER	1				
29	523341	ROD AY,ADJUSTING(PLATED)	2				
30	64163-04	WASHER,25/64X5/8X16GA	4				
31	518510	SPRING	2				
32	523342	CONNECTOR,ROD PLATED	2				
33	64151-18	NUT, HEX	2				
34	64168-2	COTTER,HAIRPIN.08X1.19	4				
35	64044-18	SCREW-SET 5/16-18 x 5/16	2				
36	64139-08	BOLT-5/16-18X3/4 WLF	8				
37	548848	SPRING,COMPRESSION	20				
38	64141-2	NUT-WLF 1/4-20	4				
39	64141-6	NUT, 5/16-18	8				
40	64151-17	LOCKNUT, HEX	20				
41	64188-62	PIN CLEVIS 5/16X2.25	2				
42	4161125	LABEL-RYAN OVAL SMALL	2				
43	4163790	LABEL-FRONT, OVERSDR	1				
44	522834	DECAL,OP INST OVERSDR	1				

FIGURE 10

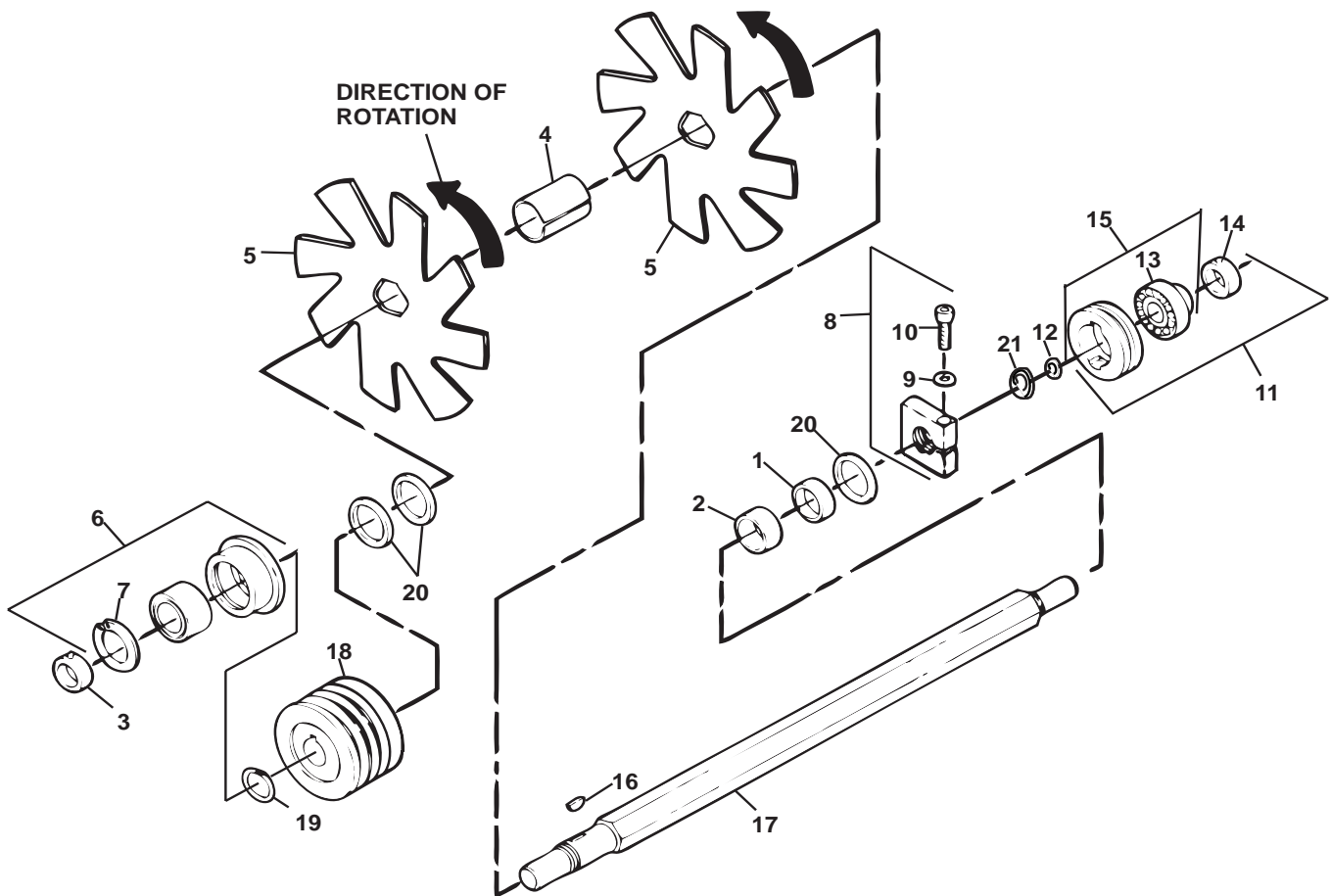

MATAWAY OVERSEEDER

REEL

FIGURE 10

ITEM	PART NO.	DESCRIPTION	QTY	ITEM	PART NO.	DESCRIPTION	QTY
1	516903	SPACER, .500 (12.7mm)	1				
2	516904	SPACER, .700 (18mm)	1				
3	521857	COLLAR,BRG LOCKING	1				
4	522835	SPACER, 1.925 (50mm)	9				
5	523293	BLADE	10				
6	544287	BLOCK AY,PILLOW (INCLUDES ITEM 7)	1				
7	548354	RING, INTERNAL RETAIN	1				
8	547778	NUT, REEL (INCLUDES ITEMS 9 & 10)	1				
9	64006-17	LOCKWASHER, 1/4"	1				
10	64189-16	SCREW, 1/4-20X1	1				
11	545640	PILLOW BLOCK AY (INCLUDES ITEM 13,14)	1				
12	64163-06	WSHR, .768/.756X1.25X14G	1				
13	521856	BEARING,BALL	1				
14	521857	COLLAR,BRG LOCKING	1				
15	544292	BEARING ASSY (INCLUDES ITEM 13)	1				
16	64164-19	KEY, WOODRUFF .19X.75 #91					
17	522542	SHAFT	1				
18	522543-3	PULLEY	1				
19	522545	RING,RETAINING	1				
20	820484	WASHER, FLAT (USE ITEM 20 AS REQUIRED SO ITEM 1 DOES NOT CONTACT THE HEX SHAFT WHEN TIGHTENED)	3				
21	95-12	WSHR, FLT 3/4 SAE ZP	1				

SCHILLER GROUNDS CARE, INC.
ONE BOB-CAT LANE
P.O. BOX 469
JOHNSON CREEK, WI 53038
920-699-2000
www.schillergc.com



©Schiller Grounds Care, Inc. 2010