



AT-16 TRACK BUGGY

OPERATIONS & PARTS MANUAL

REVISION: 05.2018 | PART #: 056800

NOTICE

This manual, or a copy of it, must be kept with the machine at all times.
There is a manual storage container located on the machine for your convenience.

Track Buggy

OPERATIONS - PARTS

MANUAL

This manual covers the products listed below:

<u>Part No.</u>	<u>Description</u>
056800	BUGGY, TRACK AT-16 ELECTRIC START

Copyright © 2013 Allen Engineering Corporation
All rights reserved

All information, specifications, and illustrations in this manual are subject to change without notice and are based on the latest information at the time of publication. No part of this manual may be reproduced or transmitted in any form or by any means, electronic or mechanical, for any purpose, without the express written permission of Allen Engineering Corporation (AEC). AEC assumes no responsibility or liability for any errors or inaccuracies that may appear in this manual.

Allen Products are covered under one or more of the following patent numbers:

U.S. Design Patents: 344,736; 400,542; 400,544; 402,998; 402,999; 403,332; 404,041; 404,042; 410,931; 413,127; 416,564; 465,897; 466,909; 474,203.

U.S. Utility Patents: 5,108,220; 5,238,323; 5,328,295; 5,352,063; 5,405,216; 5,476,342; 5,480,257; 5,480,258; 5,533,831; 5,562,361; 5,567,075; 5,613,801; 5,658,089; 5,685,667; 5,803,658; 5,816,739; 5,816,740; 5,890,833; 5,934,823; 5,967,696; 5,988,938; 5,988,939; 6,019,433; 6,019,545; 6,048,130; 6,053,660; 6,089,786; 6,106,193; 6,857,815; 5,288,166; 6,582,153 B1, 7,108,449; 7,114,876; 7,316,523; 7,690,864 B2

Canadian Patents: 2,039,893.

First Issue: January 2013

Amended: July, 2017

May, 2018 - MN 18-012, 18-015, 18-017, 18-034, 18-052, M. Wesley

AEC Manual Part No.: 056841

Printed in U.S.A.

Limited Warranty

LIMITED WARRANTY and LIMITATION OF LIABILITY

Allen Engineering Corporation ("Allen") warrants its products to be free of defects in material or workmanship for the following periods:

A. New Machines and Parts.....One Year

Warranty period begins on first day of use by End User. This first day of use is established by the date of a completed Allen Warranty Card or a Bill of Sale to the End User. All warranty is based on the following limited warranty terms and conditions, including the disclaimer of implied warranties and consequential damages.

1. Allen's obligation and liability under this warranty is limited to repairing or replacing parts if, after Allen's inspection, there is determined to be a defect in material or workmanship. Allen reserves the choice to repair or replace.
2. If Allen chooses to replace the part, it will be at no cost to the customer and will be made available to the Allen Distributor, Dealer, or Rental Center from whom the End User purchased the product.
3. Replacement or repair parts, installed in the product, are warranted only for the remainder of warranty period of the product as though they were the original parts.
4. Allen does not warranty engines. Engine warranty claims should be made directly to an authorized factory service center for the particular engine manufacturer.
5. Allen's warranty does not cover the normal maintenance of products or its components (such as engine tune-ups and oil & filter changes). The warranty also does not cover normal wear and tear items (such as belts and consumables).
6. Allen's warranty will be void if it is determined that the defect resulted from operator abuse, failure to perform normal maintenance on the product, modification to product, alterations or repairs made to the product without the written approval of Allen. Allen specifically excludes from warranty any damage to any trowels resulting from an impact to the rotors.
7. Impact damage is not covered under the Allen Gear Box warranty.
8. Allen will pay shop labor on warranty items at the Allen Shop Labor Rate in existence on the date of the warranty claim. An Allen Labor Chart will determine the time allowed to complete a repair and will govern the shop labor hours that will be allowed.
9. Allen will pay freight on warranty replacement parts at worldwide standard ground rates. No warranty replacement parts will be shipped air freight at the expense of Allen. Allen only pays outbound freight charges when sending warranty replacement parts to the customer via ground service. Allen does not pay any inbound freight. However, if Allen determines this to be a warranted item, only then will Allen reimburse the customer for inbound freight at standard ground rates.
10. ALLEN ENGINEERING CORPORATION'S WARRANTY POLICY WILL NOT COVER THE FOLLOWING: TAXES; SHOP SUPPLIES; ENVIRONMENTAL SURCHARGES; AIR FREIGHT; TRAVEL TIME; LOSS OF TIME; INCONVENIENCE; LOSS OF RENTAL REVENUE; RENTAL COSTS OF EQUIPMENT USED TO REPLACE THE PRODUCT BEING REPAIRED; LOSS OF USE OF THE PRODUCT; COMMERCIAL LOSS; OR ANY OTHER CHARGES WHATSOEVER OR ANY LIABILITIES FOR DIRECT, INCIDENTAL, OR CONSEQUENTIAL DAMAGE OR DELAY.
11. ALLEN ENGINEERING CORPORATION MAKES NO OTHER WARRANTY, EXPRESSED OR IMPLIED. THIS LIMITED WARRANTY IS IN LIEU OF THE WARRANTY OF MERCHANTABILITY AND FITNESS. THERE ARE NO OTHER WARRANTIES THAT EXTEND BEYOND THE DESCRIPTION ON THIS DOCUMENT.
12. No Allen employee or representative is authorized to change this warranty in any way or grant any other warranty unless such change is made in writing and signed by an officer of Allen Engineering Corporation.

Table of Contents

Sect No.	Title	Page
...	Limited Warranty	ii
...	Table of Contents	iii
...	Information Contained In This Manual	v
...	Dealer Information	vi
...	Ordering Parts	vii
...	Model Number - Serial Number Codes	viii
...	Unit Identification	ix
...	Technical specifications	x
...	Engine Specifications	xi
...	Machine Dimensional Specifications	xii
1.0	Safety	1-1
...	State Regulations	1-2
...	Federal Regulations	1-3
1.1	Safety Information	1-4
1.2	Safety Symbols	1-5
1.3	General Safety	1-6
1.4	Transportation Safety	1-15
2.0	Operations	2-1
	Pre-Operating Instructions	2-2
	Starting	2-4
	Operating	2-5
	Bucket Capacity	2-9
3.0	Service	3-1
	Maintenance Instructions	3-2
	Air Filter Maintenance	3-3
	Engine Oil Maintenance	3-5
	Maintenance Schedule	3-6
	Filter Replacement	3-7

Table of Contents - Continued

Sect No.	Title	Page
4.0	Parts	4-1
	Factory Service Information	4-2
	Replacement Part Procedure	4-3
	Track Tensioner and Wheel Assembly	4-4
	Track Roller Assembly	4-6
	Track Bogey Assembly	4-7
	Left Track Assembly	4-8
	Right Track Assembly	4-10
	Lever Assembly	4-12
	Hydraulic Tank Assembly	4-18
	Hydraulics	4-20
	Electrical Schematic	4-26
	Cabinet Assembly	4-28
	Engine Mount Assembly	4-30
	Stand Assembly	4-32
	Track Assembly	4-34
	Fuel Assembly	4-36
	Control Panel Assembly	4-38
	Bucket Assembly	4-40
	Skid Plate Assembly	4-42
	Handle Bar Assembly	4-43
	Decal Layout - Right	4-44
	Decal Layout - Left	4-45

Information Contained in this Manual



This manual provides information and procedures to safely operate and maintain the Allen Machine.

For your own safety and protection from personal injury, carefully read, understand, and observe the safety instructions described in this manual. Keep this manual or a copy of it with the machine at all times.

Always operate this machine in accordance with the instructions described in this manual. A well maintained piece of equipment will provide many years of trouble free operation.

This manual is divided into the following sections:

**SECTION 1
SAFETY**

**SECTION 2
OPERATIONS**

**SECTION 3
SERVICE**

**SECTION 4
PARTS**

Complete any warranty requirements as specified by the engine manufacturer in their instructions found inside the manual box located on the operator's control panel.

Your engine is not manufactured by Allen Engineering Corporation, Inc, and therefore is not covered under Allen Engineering Corporation, Inc warranty.

Your engine manufacturer should be contacted if you wish to purchase a parts manual or a repair manual for your engine.

Refer to enclosed owners engine manual for complete O&M instructions. See your battery manufacturer for battery warranty.

Dealer Information

Your Dealer has Allen Engineering Corporation trained mechanics and original Allen replacement parts. Always contact the Allen Dealer who sold you this machine for Allen Certified repairs and replacement parts.

Place Allen Dealer information below for future reference.

Dealer Name:	_____
Phone #:	(____) - ____ - _____
Address:	_____
City:	_____
State:	_____
Zip:	_____
Salesman:	_____
Mobile Phone	_____
Additional Comments:	_____



Ordering Parts

Section 4.0 contains illustrated parts lists for help in ordering replacement parts for your machine. Follow the instructions below when ordering parts to insure prompt and accurate delivery:

1. All orders for service parts - include the serial number for the machine. Shipment will be delayed if this information is not available.
2. Include correct description and part number from the "PARTS" section of this manual.
3. Specify exact shipping instructions, including the preferred routing and complete destination address.
4. DO NOT return parts to AEC without receiving written authorization from AEC. All authorized returns must be shipped pre-paid.
5. When placing an order, please contact the AEC dealer nearest you.

NOTE

All information, specifications, and illustrations in this manual are subject to change without notice and are based on the latest information at the time of publication.

VISIT US!!!



www.alleneng.com

LIKE US!!!



www.facebook.com/AllenEngineering

FOLLOW US!!!



[@alleneng](https://twitter.com/alleneng)

WATCH US!!!



www.youtube.com/AllenMachinery

Model Number - Serial Number Codes

Manufacturer's Codes:

When ordering parts or requesting service information, you will always be asked to specify the model and serial numbers of the machine. The legends below specifically defines each significant character or group of characters of the Model Number and Serial Number codes.

Model Number

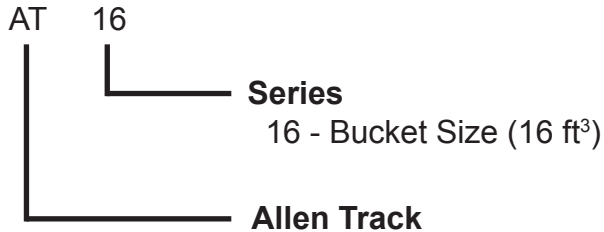

Serial Number

The serial number found on the identification plate is a ten digit format. The model number identifies your machine and will ensure that you receive the correct replacement parts.

Serial Number Example

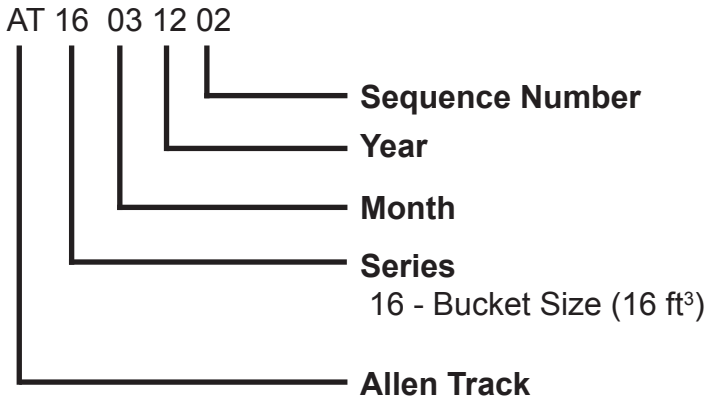

Unit Identification

Unit Identification Plate Location:

An identification plate listing the model number and the serial number is attached to each unit and is located on the bottom left hand corner of the operator control panel. See image below for serial number plate number location. This plate should not be removed at any time.

Please record the information found on this plate below so it will be available should the identification plate become lost or damaged. When ordering parts or requesting service information, you will always be asked to specify the model and serial numbers of the machine.

FILL IN FOR FUTURE REFERENCE

Model Number: _____

Serial Number: _____

Date Purchased: _____

Purchased From: _____

Serial # Plate Location



Technical Specifications

MODEL	AT16
Engine	Kohler (27 hp) Electric Start
Payload	2,500 lb. (1,134 kg)
Dimensions (L x H)	97 in. x 50 in. (246 x 127 cm)
Length (with Platform Up)	88.5 in. (225 cm)
Dimensions (Width)	47 in. (119 cm)
Wheelbase / Track Length	51 in. (130 cm)
Bucket Capacity	16 cu. ft. (0.45 cu. m)
Weight	1,475 lb. (669 kg)
Lift Cylinder	2" Diameter (51 mm)
Dump/Return Speed Empty	8 Seconds
Top Speed	6 mph (8 kph)
Fuel Capacity	6 gal. (22.7 L)

The Allen AT-16 Track Drive Power Buggies, are intended for the transportation of concrete and material handling. The Track Buggy is equipped with a low dump height which provides clearance and enables the operator to maneuver over any form height. In addition the Track Buggy has a unique tub design that reduces concrete splatter outside the polyethylene tub (bucket).

A low center of gravity has been added into the Track Buggy's design which will provide safety when maneuvering the buggy in tight areas. A 6-gallon fuel tank allows for extended uninterrupted use. Maximum speed of the Track Buggy is rated at 6 MPH.

All Track Buggy operators must have training instructions before operating the buggy. For your safety, warnings are on the buggy and in this manual. Failure to obey these warning can cause severe injury or even death.

Understand the operation and features of the Track Buggy and what conditions it will be operated in. Know the rated load capacity, speed range, braking and steering characteristics, turning radius and operating clearances. Remember that the rain, snow, ice, loose gravel, soft ground, etc., can change the operating characteristics and capabilities of the Track Buggy.

Inspect the surface over which you will travel. Look for holes, drop offs and obstacles. Look for rough spots. Look for weak spots on docks, ramps or floor. Look for oil spills, wet spots and slippery surfaces. Look for soft soil, deep mud and standing water. Watch for anything that might make you lose control or cause the buggy to tip over.

If, during pre-operation inspection or operation, the buggy is found to be in need of repair or in any way unsafe, or contributes to an unsafe condition to the operator, the matter shall be reported immediately to the designated authority, and the buggy shall not be operated until it has been restored to proper operating condition. **DO NOT** make repairs or adjustments unless specifically authorized to do so.

Engine Specifications

27 HP Kohler

MODEL	CV740-3001
Weight	108.0 lbs
Engine Displacement (cc)	725
Start Type	Electric
Engine Type	Command Pro V-Twin CV740-OHV
Rated Power (HP)	27
Torque (ft./lbs.)	42
Displacement (cu. in.)	44
Shaft Output	Vertical
Shaft Diameter (in.)	1 1/8
Shaft Length (in.)	3 5/32
Shaft End Tapped (Diameter (in.)/Threads per inch)	7/16-20
Shaft Rotation (From PTO Shaft Side)	Counterclockwise
Cylinders (qty.)	2
Cylinder Bore	Cast iron
Bore x Stroke (in.)	3.30 x 2.60
Compression Ratio	9.0:1
Cooling System	Air cooled
Air Cleaner Type	Dual element air filter w/ foam pre-cleaner
Fuel Tank	Not included
Fuel Type	Gasoline
Fuel Pump	Pulse
Fuel Filter	In line
Oil Capacity (qt.)	2
Lubrication System	Full pressure
Ignition System	Electronic
Carburetor	Fuel injection
Max. RPM	3,600
Charging System Amps	20
Muffler Included	Yes
Auto Compression Release	Yes
Bolt Circle (in.)	10
Dimensions L x W x H (in.)	21 3/16 x 17 11/16 x 14 5/16
EPA/CARB Approval (California Air Resource Board)	Yes

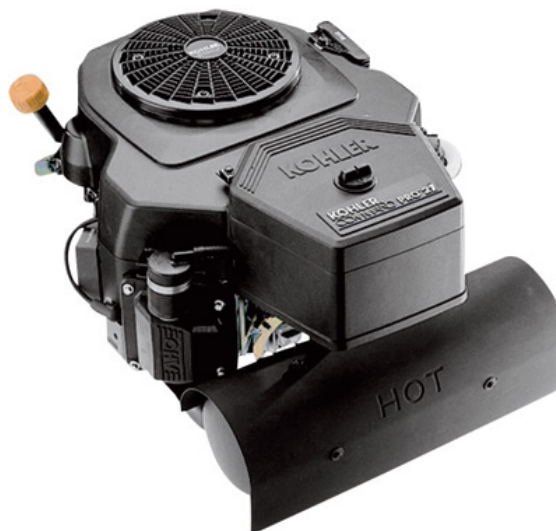

Dimensional Specifications

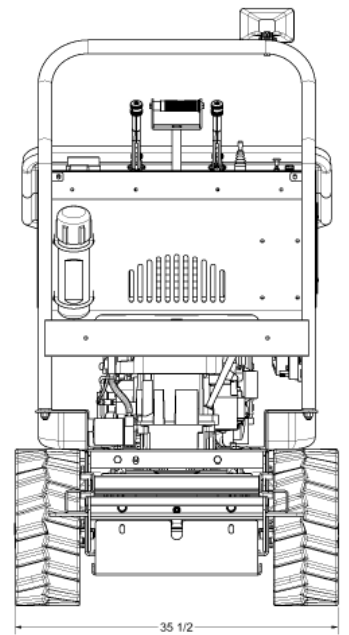
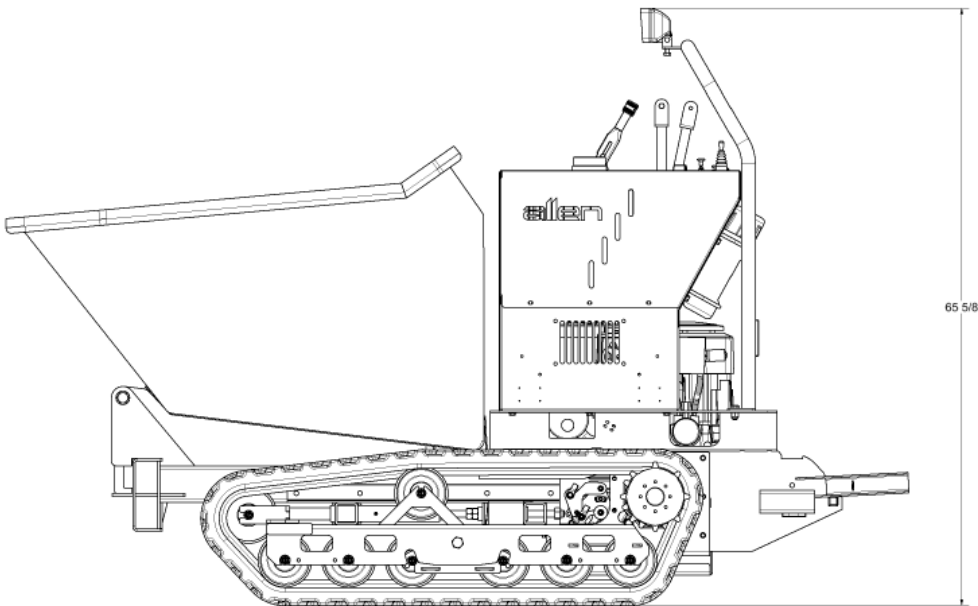
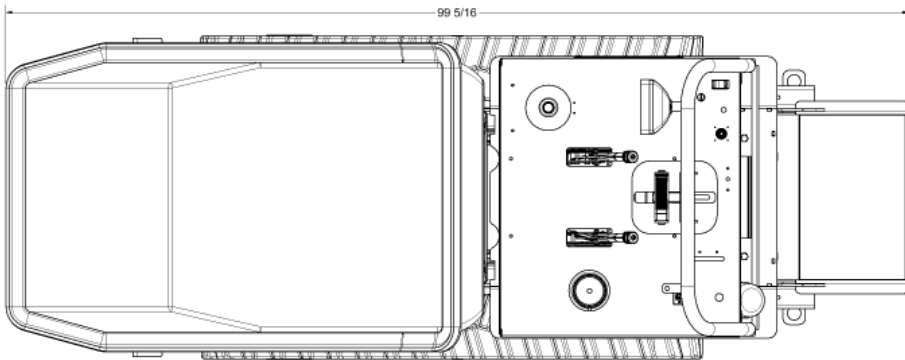

Section 1
SAFETY

SECTION 1 SAFETY

State Regulations Proposition 65 Warning



WARNING



CALIFORNIA — Proposition 65 Warning

Engine exhaust and some of its constituents, and some dust created by power sanding, sawing, grinding, drilling and other construction activities contains chemicals known to the State of California to cause cancer, birth defects and other reproductive harm. Some examples of these chemicals are:

- Lead from lead-based paints.
- Crystalline silica from bricks.
- Cement and other masonry products.
- Arsenic and chromium from chemically treated lumber.

Your risk from these exposures varies, depending on how often you do this type of work. To reduce your exposure to these chemicals: **ALWAYS** work in a well ventilated area, and work with approved safety equipment, such as dust masks that are specially designed to filter out microscopic particles.

Federal Regulations Respiratory Hazards

SECTION 1 SAFETY

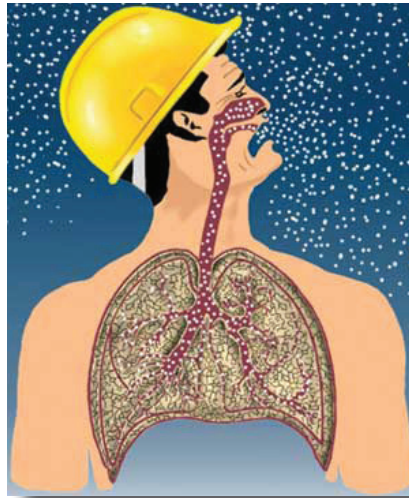

! WARNING

RESPIRATORY HAZARDS

Grinding/cutting/drilling of masonry, concrete, metal and other materials can generate dust, mists and fumes containing chemicals known to cause serious or fatal injury or illness, such as respiratory disease, cancer, birth defects or other reproductive harm. If you are unfamiliar with the risks associated with the particular process and/or material being cut or the composition of the tool being used, review the material safety data sheet and/or consult your employer, the material manufacturer/supplier, governmental agencies such as OSHA and NIOSH and other sources on hazardous materials. California and some other authorities, for instance, have published lists of substances known to cause cancer, reproductive toxicity, or other harmful effects.

Control dust, mist and fumes at the source where possible. In this regard use good work practices and follow the recommendations of the manufacturers or suppliers, OSHA/NIOSH, and occupational and trade associations. Water should be used for dust suppression when wet cutting is feasible. When the hazards from inhalation of dust, mists and fumes cannot be eliminated, the operator and any bystanders should always wear a respirator approved by NIOSH/MSHA for the materials being used.

! WARNING

SILICOSIS WARNING

Grinding/cutting/drilling of masonry, concrete, metal and other materials with silica in their composition may give off dust or mists containing crystalline silica. Silica is a basic component of sand, quartz, brick clay, granite and numerous other minerals and rocks. Repeated and/or substantial inhalation of airborne crystalline silica can cause serious or fatal respiratory diseases, including silicosis. In addition, California and some other authorities have listed respirable crystalline silica as a substance known to cause cancer. When cutting such materials, always follow the respiratory precautions mentioned above.

SECTION 1 SAFETY

1.1 Safety Information

Do not operate or service the equipment before reading the entire manual. Safety precautions should be followed at all times when operating this equipment. Failure to read and understand the safety messages and operating instructions could result in injury to yourself and others.

SAFETY NOTES

The four safety notes shown below will inform you about potential hazards that could injure you or others. The safety notes specifically address the level of exposure to the operator and are preceded by one of four words: DANGER, WARNING, CAUTION or NOTICE.



Indicates a hazardous situation which, if not avoided, **will** result in death or serious injury.



Indicates a hazardous situation which, if not avoided, **could** result in death or serious injury.



Indicates a hazardous situation which, if not avoided, could result in minor or moderate injury.









Addresses practices not related to personal injury.



1.2 Safety Symbols

SECTION 1 SAFETY

Potential hazards associated with the operation of this equipment will be referenced with hazard symbols which may appear throughout this manual in conjunction with safety notes.

Symbol	Safety Hazard
	Lethal exhaust gas hazards
	Explosive fuel hazards
	Burn hazards
	Rotating parts/crush hazards
	Pressurized fluid hazards
	Hydraulic fluid hazards

SECTION 1 SAFETY

1.3 General Safety

- **NEVER** operate this equipment without proper protective clothing, shatterproof glasses, respiratory protection, hearing protection, steel-toed boots and other protective devices required by the job or city and state regulations.



- **ALWAYS** avoid wearing jewelry or loose fitting clothes that may snag on the controls or moving parts as this can cause serious injury.

- **NEVER** operate this equipment when not feeling well due to fatigue, illness or when under medication.



- **NEVER** operate this equipment under the influence of drugs or alcohol.



- **ALWAYS** clear the work area of any debris, tools, etc. that would constitute a hazard while the equipment is in operation.

- No one other than the operator is to be in the working area when the equipment is in operation.
- **DO NOT** use the equipment for any purpose other than its intended purposes or applications.
- This equipment should only be operated by trained and qualified personnel 18 years of age and older.
- Whenever necessary, replace nameplate, operation and safety decals when they become difficult to read.
- AEC does not assume responsibility for any accident due to equipment modifications. Unauthorized equipment modification will void all warranties.
- **NEVER** use accessories or attachments that are not recommended by AEC for this equipment. Damage to the equipment and/or injury to user may result.

- **ALWAYS** know the location of the nearest fire extinguisher.



- **ALWAYS** know the location of the nearest first aid kit.



1.3 General Safety (cont'd)

SECTION 1 SAFETY

- **ALWAYS** know the location of the nearest phone or keep a phone on the job site. Also, know the phone numbers of the nearest ambulance, doctor and fire department. This information will be invaluable in the case of an emergency.



- Engine fuel exhaust gases contain poisonous carbon monoxide. This gas is colorless and odorless, and can cause death if inhaled.
- The engine of this equipment requires an adequate free flow of cooling air. never operate this equipment in any enclosed or narrow area where free flow of the air is restricted. If the air flow is restricted it will cause injury to people and property and serious damage to the equipment or engine.
- **NEVER** operate the equipment in an explosive atmosphere or near combustible materials. An explosion or fire could result causing severe bodily harm or even death.



- If applicable, never use your hand to find hydraulic leaks. Use a piece of wood or cardboard. Hydraulic fluid injected into the skin must be treated by a knowledgeable physician immediately or severe injury or death can occur.



- **ALWAYS** keep clear of rotating or moving parts while operating the buggy.



- **NEVER** disconnect any emergency or safety devices. These devices are intended for operator safety. Disconnection of these devices can cause severe injury, bodily harm or even death. Disconnection of any of these devices will void all warranties.



- **NEVER** allow passengers or riders on the buggy during operation.
- **NEVER** lubricate components or attempt service on a running machine.

SECTION 1 SAFETY

1.3 General Safety (cont'd)

NOTICE

- **ALWAYS** keep the machine in proper running condition.
- Fix damage to machine and replace any broken parts immediately.
- **ALWAYS** store equipment properly when it is not being used. Equipment should be stored in a clean, dry location out of the reach of children and unauthorized personnel.

WARNING

- **DO NOT** place hands or fingers inside engine compartment when engine is running.
- **NEVER** operate the engine with heat shields or guards removed.
- Keep fingers, hands hair and clothing away from all moving parts to prevent injury.
- Use caution when operating at high speeds. It is necessary to decrease speed when turning, approaching objects or people, and when conditions call for conservative driving, i.e. inclines, declines, uneven surfaces, blind corners, or other obstacles that may obscure vision.
- When operating the dumping feature of the machine, the operator and other personnel need to stay clear of the bucket when it is dumping its contents and afterwards when the bucket is returning to the stored position.
- **DO NOT** remove the engine oil drain plug while the engine is hot. Hot oil will gush out of the oil tank and severely scald any persons in the general area of the screed.



CAUTION

- **NEVER** touch the hot exhaust manifold, muffler or cylinder. Allow these parts to cool before servicing equipment.



NOTICE

- **NEVER** run engine without an air filter or with a dirty air filter. Severe engine damage may occur. Service air filter frequently to prevent engine malfunction.
- **NEVER** tamper with the factory settings of the engine or engine governor. Damage to the engine or equipment can result if operating in speed ranges above the maximum allowable.



1.3 General Safety (cont'd)

SECTION 1 SAFETY

DANGER

- **DO NOT** start the engine near spilled fuel or combustible fluids. Fuel is extremely flammable and its vapors can cause an explosion if ignited.
- **ALWAYS** refuel in a well-ventilated area, away from sparks and open flames.
- **ALWAYS** use extreme caution when working with flammable liquids.
- **DO NOT** fill the fuel tank while the engine is running or hot.
- **DO NOT** overfill tank, since spilled fuel could ignite if it comes into contact with hot engine parts or sparks from the ignition system.
- Store fuel in appropriate containers, in well-ventilated areas and away from sparks and flames.
- **NEVER** use fuel as a cleaning agent.
- **DO NOT** smoke around or near the equipment. Fire or explosion could result from fuel vapors or if fuel is spilled on a hot engine.



DANGER

- **DO NOT** drop the battery. There is a possibility that the battery will explode.
- **DO NOT** expose the battery to open flames, sparks, cigarettes, etc. The battery contains combustible gases and liquids. If these gases and liquids come into contact with a flame or spark, an explosion could occur.



WARNING

- **ALWAYS** wear safety glasses when handling the battery to avoid eye irritation. The battery contains acids that can cause injury to the eyes and skin.
- Use well-insulated gloves when picking up the battery.
- **ALWAYS** keep the battery charged. If the battery is not charged, combustible gas will build up.
- **DO NOT** charge battery if frozen. Battery can explode. When frozen, warm the battery to at least 61°F (16°C).



SECTION 1 SAFETY

1.3 General Safety (cont'd)

- **ALWAYS** recharge the battery in a well-ventilated environment to avoid the risk of a dangerous concentration of combustible gases.

- If the battery liquid (dilute sulfuric acid) comes into contact with clothing or skin, rinse skin or clothing immediately with plenty of water.









- If the battery liquid (dilute sulfuric acid) comes into contact with eyes, rinse eyes immediately with plenty of water and contact the nearest doctor or hospital to seek medical attention.



CAUTION

- **ALWAYS** disconnect the negative battery terminal before performing service on the equipment.
- **ALWAYS** keep battery cables in good working condition. Repair or replace all worn cables.
- Only load or dump the bucket on flat, level ground or the buggy may tip over.
- **DO NOT** load the buggy beyond its rated capacity.
- The bucket should not be filled to its rated capacity when transporting material up or down slopes, on uneven surfaces, or on varying ground conditions to avoid spilling material out of the bucket.
- Side slope operation is not permitted.
- Walk around the buggy before starting it to see if any items are worn, damaged, leaking, etc. that may make the buggy dangerous to operate.
- Stop and inspect the equipment if you strike an object. If necessary, make repairs before restarting.
- **ALWAYS** check that all controls are functioning properly immediately after start-up!
- **DO NOT** operate machine unless all controls operate correctly.
- **ALWAYS** use caution when operating near the edges of pits, trenches or platforms. Check to be sure ground surface is stable enough to support the weight of the machine and operator and there is no danger of the machine sliding, falling or tipping.

1.3 General Safety (cont'd)

SECTION 1 SAFETY

 WARNING	ADVERTENCIA
 Electric shock hazard. Keep away from electric power lines and utility poles.	Peligro de electrocución. Manténgase alejado de los cables de energía eléctrica y postes de electricidad.
 Crush hazard. Beware of obstacles when reversing or turning. Always operate slowly and keep six feet or more clearance.	Peligro de aplastamiento. Durante la marcha atrás girando tenga cuidado con los obstáculos siempre. Operar despacio y mantenerse seis pies o más espacio.
 Moving belts can entangle hands and arms. Keep hands away to avoid injury.	Cintas transportadoras pueden enredar manos y los brazos. Mantener las manos alejadas para evitar lesiones.
 Operator must always keep one hand on the handle.	El operador debe mantener siempre una mano en el mango.
 Hot Surface. Do NOT touch.	De superficie caliente. NO TOCAR.
 Read and FULLY understand the operator's manual before use or maintenance.	COMPLETAMENTE comprender el manual del operador antes de su uso o mantenimiento.

 WARNING	ADVERTENCIA
 Upset hazard.	Voltear peligro.
 <ul style="list-style-type: none"> Accelerate or decelerate slowly. Sudden starts, stops, or turns can cause tip-over. Never operate on slope in excess of 20 degrees. Avoid running over obstacles. Hold onto guide rail at all times. Keep feet on foot platform (step) at all times. 	<ul style="list-style-type: none"> Acelerar o desacelerar lentamente. Arranques bruscos, paradas o giros puede causar un vuelco. Nunca utilice en pendientes de más de 20 grados. Evite conducir sobre obstáculos. Sujete carril guía siempre Mantenga los pies sobre la plataforma para los pies siempre.
 Power Sources. Hydraulic and electric power sources are present. Lockout ALL energy sources before servicing.	Fuentes de alimentación. hidráulica y energía eléctrica fuentes son presente. interrupción de energía usando candado TODAS las fuentes de energía antes de darle mantenimiento.
<p>UNDERCARRIAGE MAINTENANCE</p> <p>Maintaining the proper track tension is critical for minimizing downtime and repair costs. Inspect the tracks and undercarriage components daily. Overly worn or damaged components can affect the track performance and shorten the useful life of the tracks. Idlers and rollers are permanently sealed and lubricated but they, along with tracks and sprockets should be replaced periodically depending on wear. The front and rear rollers will wear more quickly than the others. Rotating the positions of the rollers periodically will lengthen the useful life. The rollers need to be replaced when the flanges are worn thin, have broken or sharp edges, or visible dents. Sprockets can be rotated from side to side when worn to put the opposite side of the teeth in contact with the bars in the tracks.</p> <ul style="list-style-type: none"> Keep the undercarriage clean of mud and debris. Also any fluids like oil or grease should be cleaned off immediately. Minimize high speed operation. Alternate turning direction. Avoid contacting the track sidewalls with hard surfaces while operating. Avoid working on crowns, depressions, or side slopes. Limit the use of the machine on rough rocky surfaces or gravel. Limit traveling on concrete or asphalt surfaces when loaded. When traveling over these surfaces avoid making sharp turns. The extra stress from turning on these types of surfaces can cause premature stretching of the tracks and de-tracking. When the machine is not in use, store out of rain and direct sunlight. 	

SECTION 1 SAFETY

1.3 General Safety (cont'd)

**MAX. LOADING CAPACITY
2500 LBS (1134 KG)**

MACHINE WEIGHT:	1500 LBS (682 KG)
MAX LOADING CAPACITY:	2500 LBS (1134 KG)
RATED OUTPUT:	27 HP (20 KW)
DRIVE BELTS:	BX41
HYDRAULIC LIFT BELT:	A45
SERVICE SCHEDULE	
ENGINE OIL:	10W-30 1.8 QT (1.7 L) CHANGE EVERY 50 HRS
HYDRAULIC OIL:	20W-50 4 GAL (15 L) INITIAL CHANGE AT 100 HRS, EVERY 400 HRS THEREAFTER.
GREASE POINTS:	EVERY 50 HRS

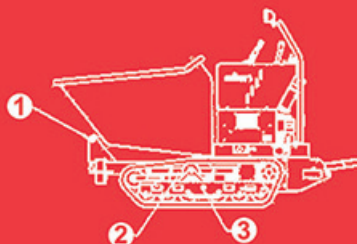

<p>WORK PRIMERA</p> <p>↑</p> <p>GEAR PALANCA DE CAMBIOS</p> <p>↓</p> <p>TRANSPORT TRANSPORTE</p>	<p>⚠ WARNING • ADVERTENCIA</p> <p>USE TRANSPORT SPEED ON SMOOTH, LEVEL SURFACE - UNLOADED ONLY</p> <p>USO DE VELOCIDAD DE TRANSPORTE EN UNIFORME, SUPERFICIE DE NIVEL - SIN CARGA SOLAMENTE</p>	<p>UNLOCK ABRIR CERRADURA</p> <p>↑</p> <p>BRAKE FRENO</p> <p>↓</p> <p>LOCK CERRADURA</p>
	<p>⚠ CAUTION • PRECAUCIÓN</p> <p>MUST BE LOCKED TO START</p> <p>DEBE ESTAR ASEGURADO PARA ARRANCAR EL MOTOR</p>	
	<p> 98 ^{LWA} dB</p>	

 DANGER

FLAMMABLE FUEL

BEFORE ADDING FUEL:

- SHUT ENGINE OFF.
- LET ENGINE COOL OFF A MINIMUM OF 5 MINUTES.
- EXTINGUISH SMOKING MATERIALS.
- USE FUNNEL.

WHILE ADDING FUEL:

- DO NOT OVERFILL.

**A HOT ENGINE CAN IGNITE
SPILLED FUEL.**

AFTER ADDING FUEL:

- REPLACE FUEL CAP.

Safety Instructions

A. Do not operate this machine before reading all labels and the operating instructions located in the plastic tube in the engine compartment.

B. Inspect this equipment daily and make any necessary repairs or adjustments before operating. (See manual)

 DANGER

 DANGER

C. **BEFORE ADDING FUEL: SHUT ENGINE OFF AND ALLOW TO COOL FOR 5 MINUTES, EXTINGUISH ALL SMOKING MATERIALS, USE FUNNEL TO FILL BUT DO NOT OVERFILL, REPLACE FUEL CAP. A HOT ENGINE MAY IGNITE SPILLED FUEL - EXERCISE EXTREME CAUTION WHEN FUELING.**

D. **DO NOT START OR OPERATE THIS EQUIPMENT IN UNVENTILATED AREAS. THE ENGINE ON THIS MACHINE PRODUCES CARBON MONOXIDE AND HYDROCARBON EMISSIONS THROUGH ITS EXHAUST. INHALATION OF THIS GAS CAN CAUSE SERIOUS INJURY OR DEATH.**

E. This equipment must only be operated by trained personnel who fully understand its safe operation. Each operator must be able to identify any unsafe work site conditions and report those conditions to his supervisor. Under all conditions, the operator is solely responsible for safe operation.

1. Identify and avoid any grade or slope conditions that may cause this equipment to tip.
2. Identify and adhere to all safe load requirements. See SAFETY AND OPERATION REQUIREMENTS below.
3. Avoid excessive speed and reckless operation.
4. Do not dump while moving. Dump only when buggy is on a level surface and not moving.
5. Do not leave operator's station unless engine is off and parking brake is locked.
6. Do not allow riders. The AT16 is designed for transportation of operator only.

SAFETY AND OPERATION REQUIREMENTS

	<small>AT16</small>
Max. Net Payload	2500 lb.
Max. Load Height from Ground	48"
Max. Vehicle GVW	3975 lb.

SECTION 1 SAFETY

1.3 General Safety (cont'd)

OPERATING INSTRUCTIONS

1. To start engine, read the instructions in the Kohler engine manual located in the plastic tube on the front panel of the machine. When using this machine in cold weather, always allow the engine to run at idle speed for at least 5 minutes to warm the engine and hydraulic oil to operating temperatures.
2. To drive and stop equipment:
 - A) With parking brake engaged and directional control in center position, increase the engine speed to full throttle using the throttle lever on the left side of the control panel.
 - B) Release the parking brake.
 - C) Select the operating range by placing the control handle into either the WORK or TRANSPORT POSITION. Use TRANSPORT position only when the machine is unloaded and operating on a smooth level surface.
 - D) Select the desired direction of travel with the DIRECTIONAL CONTROL HANDLE located in the center of the control panel. Push the handle forward to move forward or pull it toward you to move backward. The speed of the machine will be determined by how far you move the handle. Steer the machine by twisting the handle in the desired direction.
 - E) To slow or stop the machine, move the DIRECTIONAL CONTROL HANDLE toward the center position. When the machine is stopped for any reason, engage the parking brake.
3. To operate the bucket:
 - A) To dump the bucket depress the front side of the dump control rocker switch and hold until the bucket has reached the desired angle.
 - B) To retract the bucket, depress the back side of the dump control rocker switch and hold until the bucket has returned to the down position.
4. To engage the parking brake, pull the handle back toward the operator until it locks. To disengage the brake, push the handle forward.



DO NOT TURN THE BUGGY WHEN TRAVELING ON A GRADE. TRAVEL IN A STRAIGHT LINE EITHER UP OR DOWN THE GRADE. WHEN THE BUCKET IS EMPTY, TRAVEL UP GRADES BACKWARDS AND DOWN GRADES FORWARD, KEEPING THE BUCKET ON THE DOWNHILL SIDE. WHEN THE BUCKET IS LOADED, TRAVEL UP GRADES FORWARD AND DOWN GRADES BACKWARDS, KEEPING THE BUCKET ON THE UPHILL SIDE. NEVER ATTEMPT TO CLIMB GRADES GREATER THAN 20°.

CAUTION

- When lifting the buggy, all personnel must be clear of the machine.
- **DO NOT** stand near or under the machine while it is being lifted.
- **DO NOT** lift the buggy with the bucket loaded.

Lifting instructions using a hoist:

- Make sure the bucket is empty, raise it to the dump position, and turn off the engine.
- Place slings, chains or hooks through each lifting eye on the machine. Use a sling or chains with a minimum length of 2 meters (6 feet) on each leg, connected to a central lifting device. Ensure that all lifting devices have sufficient weight-bearing capacity.
- Lift the buggy a few inches off of the ground and check to see how it is balanced. If the buggy is not fairly level, lower the buggy onto the ground, partially lower or raise the bucket, and turn off the engine. Repeat this procedure until the buggy is levelled out.

Note: Position of the bucket is dependant on several factors, including position of the operator's platform, amount of fuel in the gas tank, etc.

- **ALWAYS** shutdown engine before transporting.

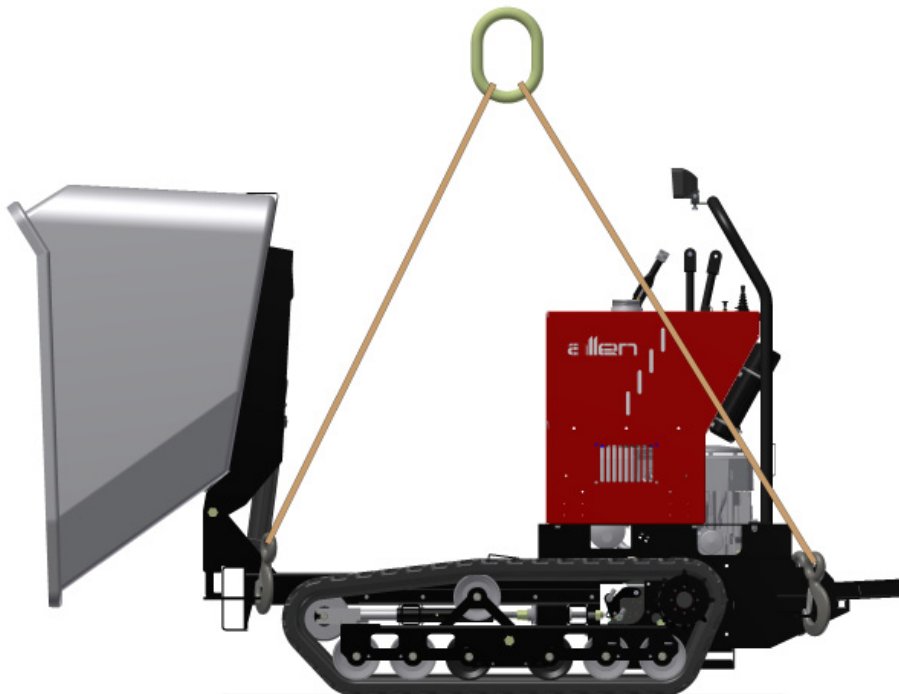

SECTION 1 SAFETY

1.4 Transportation Safety (cont'd)

- Make sure the hitch and coupling of the towing vehicle are rated equal to, or greater than the trailer “gross vehicle weight rating.”
- **ALWAYS** inspect the hitch and coupling for wear. Never tow a trailer with defective hitches, couplings, chains, etc.
- Check the tire air pressure on both towing vehicle and trailer. Trailer tires should be inflated to 50 psi cold. Also check the tire tread wear on both vehicles.
- **ALWAYS** make sure the trailer is equipped with a safety chain.
- **ALWAYS** properly attach trailer’s safety chains to towing vehicle.
- **ALWAYS** make sure the vehicle and trailer directional, backup, brake and trailer lights are connected and working properly.
- DOT Requirements include the following:
 - Connect and test electric brake operation.
 - Secure portable power cables in cable tray with tie wraps.
- The maximum speed for highway towing is 55 MPH unless posted otherwise. Recommended off-road towing is not to exceed 15 MPH or less depending on type of terrain.
- Avoid sudden stops and starts. This can cause skidding, or jack-knifing. Smooth, gradual starts and stops will improve towing.
- Avoid sharp turns to prevent rolling.
- Trailer should be adjusted to a level position at all times when towing.
- Raise and lock trailer wheel stand in up position when towing.
- Place chock blocks underneath wheel to prevent rolling while parked.
- Place support blocks underneath the trailer’s bumper to prevent tipping while parked.
- Use the trailer’s swivel jack to adjust the trailer height to a level position while parked.

Section 2
OPERATIONS

SECTION 2 OPERATIONS

Pre-Operating Instructions

Before operation each day ensure the following:

- All guards, side screens and panels are in place.
- All safety and information signs are in place and legible.
- Engine and hydraulic oil levels are correct.
- Check battery level
- Check for hydraulic leaks.
- Check all operating controls for proper operation and adjustment.
- Check speed control operation before and after starting engine for proper operation.
- Transmission oil level. Add oil as required.
- Rubber track is in good condition and working properly.
- Hand operated brake for proper operation.
- The steering, left and right.

Note: If there is any indication that faulty equipment exists, shutdown safely, inform the proper authority and **DO NOT** operate the power buggy until the problem has been fixed.

- Remove loose objects that could interfere with operation.

Learn as much as possible about the work area before operation. Walk around the worksite and inspect the terrain that you will be traveling on.

Make a note of surfaces to be avoided, including:

- Holes, Drop-offs, Banks, Ditches, Trenches, Slopes, or Undercut High Banks.
- Obstacles.
- Soft mud and standing water.
- Oil spills and slippery surfaces.

Note: If any of the above conditions exist in the work area, correct the condition before operating. If the condition cannot be corrected, avoid operation in the problem area. When operating on docks, ramps, or floors, check for weak spots. Clear away trash and debris. When required, check the power buggy's maximum fully loaded ground pressure weight if operating on a hollow floor system.

Watch for conditions that could cause:

- Loss of control
- A collision
- Tipover

Check overhead clearances. Know the size of doorways and canopies. Know exactly how much clearance you have under power lines and telephone lines. All local, state/provincial, and federal regulations must be met before approaching power lines, overhead or underground cables or other power sources with any part of your power buggy. **DO NOT** operate the machine near energized power lines. **ALWAYS** contact the electrical power company when operating near power lines. The lines should be moved, insulated, disconnected, or de-energized and grounded before operating in the area. Keep all parts of the machine at least 50 feet away from power lines.

Before you operate, know how and where you will travel, turn, and pickup loads.

Choose a smooth level route to prevent possible tipover or loss of load. If possible, avoid crossing the following: Ruts, ditches, curbs, and exposed railroad tracks.

Note: When these conditions cannot be avoided travel very slowly and with extreme caution. Know where there are any blind corner conditions on the worksite. Before turning a blind corner, stop, and then proceed slowly.

ALWAYS maintain safe distances between the power buggy and other equipment that may be on the worksite.

Know the weights of all loads you may be expected to transport before attempting to load them. Avoid loads of loose material if possible. To avoid injury to personnel or damage to nearby equipment and fixtures watch front and rear machine clearance when driving straight and when turning.

Choose a level, parking area out of traffic to park the power buggy at the end of the day. If the area is on a slope or incline, position the power buggy at right angles to the slope, set the hand brake, lower the bucket onto the frame assembly.

For safe operation of the power buggy you must be a qualified and authorized operator. To be qualified, you must understand the written instructions supplied in the operator/maintenance manual, have training (including actual operation of this machine), and know the safety rules and regulations for the jobsite.

An operator must not use drugs or alcohol which can affect his alertness and coordination. An operator on prescription or over-the-counter drugs needs medical approval to safely operate these machines.

SECTION 2 OPERATIONS

Starting Instructions

Make sure that the parking brake is fully applied and in the locked position.

Make sure fuel valve is open on fuel tank.

Note: If engine is cold, move choke lever to close position. If engine is hot, set choke to open position.

Move the throttle lever slightly towards the bucket.

Pull the E-stop button out.

Turn the key switch to “ON” position.

Hold switch in “START” position until engine starts. Do not hold switch in “START” position for more than 5 seconds.

Note: If the engine does not start, wait 10 seconds, and turn switch to “START” again.

When engine starts, allow switch to return to “ON” position.

As the engine warms up, gradually move the choke lever to the OPEN position.

Position the throttle lever to the maximum engine speed of 3600 rpm, release the parking brake and move into operation.

Read the instructions in the Kohler engine manual located in the plastic tube on the front panel of the machine. When using this machine in cold weather, always allow the engine to run at idle speed for at least 5 minutes to warm the engine and hydraulic oil to operating temperatures.

To drive and stop equipment:

A) With parking brake engaged and directional control in center position, increase the engine speed to full throttle using the throttle lever on the left side of the control panel.

B) Release the parking brake.

C) Select the operating range by placing the control handle into either the **WORK** or **TRANSPORT** position. Use **TRANSPORT** position only when the machine is unloaded and operating on a smooth level surface.

D) Select the desired direction of travel with the **DIRECTIONAL CONTROL HANDLE** located in the center of the control panel. Push the handle forward to move forward or pull it toward you to move backward. The speed of the machine will be determined by how far you move the handle. Steer the machine by twisting the handle in the desired direction.

E) To slow or stop the machine, move the **DIRECTIONAL CONTROL HANDLE** toward the center position. When the machine is stopped for any reason, engage the parking brake.

To operate the bucket:

A) To dump the bucket, depress the front side of the dump control rocker switch and hold until the bucket has reached the desired angle.

B) To retract the bucket, depress the back side of the dump control rocker switch and hold until the bucket has returned to the down position.

To engage the parking brake, pull the handle back toward the operator until it locks. To disengage the brake, push the handle forward.

DO NOT TURN THE BUGGY WHEN TRAVELING ON A GRADE. TRAVEL IN A STRAIGHT LINE EITHER UP OR DOWN THE GRADE. WHEN THE BUCKET IS EMPTY, TRAVEL UP GRADES BACKWARDS AND DOWN GRADES FORWARD KEEPING THE BUCKET ON THE DOWNHILL SIDE.

WHEN THE BUCKET IS LOADED, TRAVEL UP GRADES FORWARD AND DOWN GRADES BACKWARDS KEEPING THE BUCKET ON THE UPHILL SIDE. NEVER ATTEMPT TO CLIMB GRADES GREATER THAN 20°.

SECTION 2 OPERATIONS

Operating Instructions - cont'd

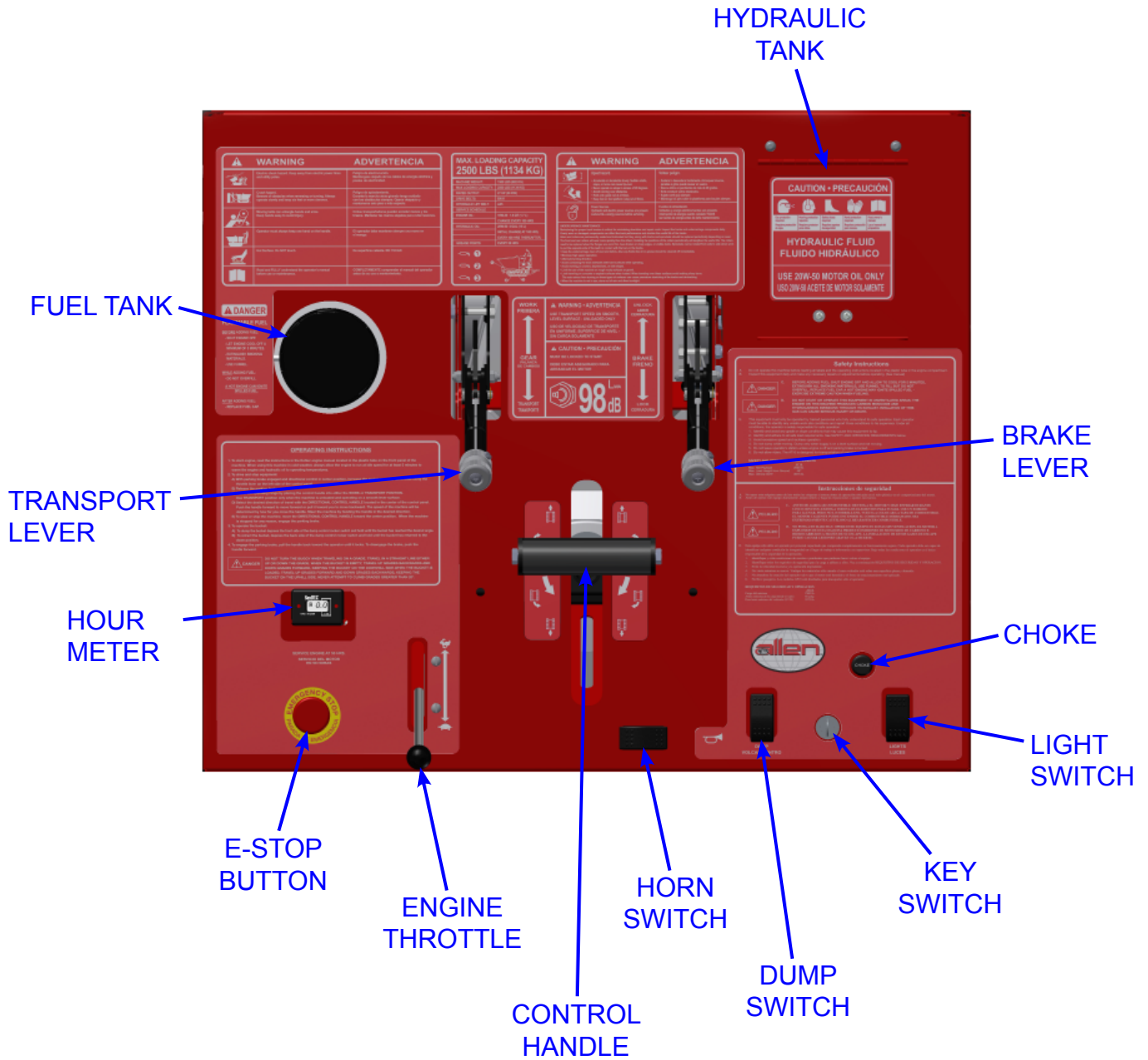

Keep personnel clear of the buggy during travel.

Do not allow anyone to stand/pass in front of the buggy during travel.

Do not approach personnel standing in front of fixed objects. Do not allow others to ride on the buggy.

Test the controls for proper operation. Be certain you can control both speed and direction before moving.

Keep both hands on the steering handle during travel.

Avoid sudden starts, stops and direction changes.

Ensure that all surfaces are capable of supporting the buggy and load.

Look for and avoid oil spills, wet or slippery surfaces that may cause loss of control.

Maintain clearances from obstacles.

Make sure aisle, ramps, doorways and passages are clear.

Operate the controls smoothly. Don't jerk the steering control.

Avoid sudden stops, starts, turns, or changes in direction.

NEVER cowboy or play games with the machine.

NEVER attempt to work the controls except from operator's position at the rear of the machine.

NEVER leave the power buggy unattended with a bucket or platform in the raised position.

Important: If the engine has been under heavy load, operate the engine at 1/2 to 3/4 throttle for three to five extra minutes before stopping the engine. Cool down applied when needed will extend engine life.

Slow down for turns, ramps, dips, uneven, or slippery surfaces and in congested areas.

Avoid excessively steep slopes or unstable surfaces. If you must drive on a slope, proceed with extreme caution. **DO NOT**, under any circumstances, drive across excessively steep slopes.

SECTION 2 OPERATIONS

Operating Instructions - cont'd

If possible, plan to load, unload, and turn on flat, level ground.

Be sure there is enough clearance for traveling. Watch the front and side clearances when turning.

Handle only stable and properly arranged loads. When handling off-center loads which cannot be centered, operate with extra caution.

Handle only loads within the capacity of the buggy.

Buggy should be operated at full speed only when traveling on a flat and level surface. When traveling on surfaces that are not flat and level, DO NOT exceed a creep speed of 10 feet in 5 seconds (120 feet per minute or 1.36 miles per hour), because the buggy does not have a speedometer, always apply good judgment when determining a safe and proper creep speed.

Do not ride on buggy if the buggy is to travel on uneven/rough terrain. Instead, raise and secure the platform and walk behind the buggy. Check to make certain that the mounting bolts are sufficiently tight to retain it in that position. Do not exceed creep speed.

Do not dump buggy when facing downhill on slope.

Do not stand in front of or alongside the buggy where you intend to unload.

Do not dump buggy towards other personnel.

Do not touch, lean on or reach through the dump mechanisms.

NEVER operate machine on side slopes. The machine may roll over, even on stable ground.



OUR MISSION STATEMENT

Our Mission is to provide superior quality products (manufactured in a safe and efficient environment by highly trained and dedicated personnel), on-time deliveries, with reactive and knowledgeable customer service.

OUR QUALITY POLICY

The Allen Engineering Team is fully committed to exceeding customer expectations for the quality of the products and services provided through the continuous improvement process of reducing waste, defects, and variability in everything we do.

OUR VISION

Our Vision is to be a world-class manufacturer of concrete placing and finishing equipment.

Section 3
SERVICE

SECTION 3 SERVICE

Maintenance Instructions

Maintenance described in this section represents minimum requirements for continuous satisfactory operation of the machine.

Because improperly maintained machines are hazardous, it is extremely important that only qualified mechanics perform maintenance work.

It is imperative that only genuine AEC parts are used if replacement is needed as substituted parts in critical areas may place the operator at risk.

It is recommended that a regular maintenance schedule be followed for mechanical adjustments as well as for lubrication.

Use a preventative maintenance program to catch and correct many serious problems before they occur. The preventative maintenance schedule contained herein gives a daily, weekly, monthly, semi-annually, annually, and break-in 100 hours minimum requirement to keep your buggy running for years. The lubrication chart contained herein is one part of buggy preventative maintenance.

Because regular maintenance cannot be controlled by the manufacturer or by the distributor, it must ultimately be the responsibility of the owner.

Your AEC dealer stands ready to assist in the event of operational difficulties. However, most adjustments and/or repair can be readily performed by the user.

The instructions provided in this section will facilitate the maintenance of the AEC equipment to operate at peak efficiency.

Pre-Cleaner Maintenance Procedure

This engine is equipped with a large capacity, dual element air filter—an oiled, foam pre-cleaner surrounds a high density paper element.

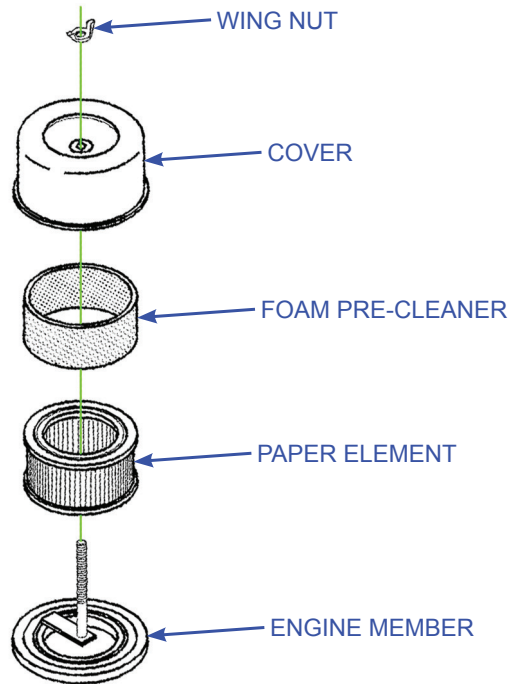

Every **25 hours** of operating time (more often under extremely dusty or dirty conditions) the oiled, foam pre-cleaner needs washing and oiling. Remove, wash, dry and oil the pre-cleaner and replace as follows:

- Raise the bucket.
- Un-bolt and remove the rear engine housing cover and access the air filter from the rear. Remove wing nut, air filter cover and paper element with foam pre-cleaner.
- Remove foam pre-cleaner from the paper element.
- Carefully check both elements for holes or tears and replace if damaged.
- Wash the foam pre-cleaner element in a solution of household detergent and warm water. Then, rinse thoroughly removing all soap and squeeze out excess water; **DO NOT** wring. Allow the element to dry thoroughly.

Note: The engine will smoke during initial start-up if too much oil is left in the foam.

- Soak the foam pre-cleaner element in a clean engine oil, and squeeze out the excess oil. (Use paper towel or similar absorbent tissue to blot/squeeze out excess oil.) **DO NOT** wring.
- Install pre-cleaner over paper air filter element.
- Install the air filter, air filter cover and wing nut. The wing nut must be finger tightened 1/2 to 1 full turn after the nut contacts cover. **DO NOT** overtighten.
- Install the engine housing cover.
- Lower the bucket.

SECTION 3 SERVICE

Air Filter Maintenance - cont'd

Paper Element Maintenance Procedure

Every **100 operating hours** (more often under extremely dusty or dirty conditions) clean or replace the paper element as follows:

- Raise the bucket.
- Unlatch and remove the engine housing cover and access the air filter from the front. Remove wing nut, air filter cover and paper element with foam pre-cleaner.
- Remove foam pre-cleaner from paper element.
- Clean the foam pre-cleaner following the Pre-Cleaner Maintenance Procedure.
- Tap the element lightly several times on a hard surface to remove excess dirt, or blow compressed air through the filter from the inside out. **NEVER** try to brush the dirt off; brushing will force dirt into the fibers. Replace the paper element if it is excessively dirty with **Part# 45 083 02**.
- When dirty or damaged, replace with the correct part number filter element. Carefully handle new element—**DO NOT** use if surfaces are damaged.
- With air filter disassembled, check the filter base plate to make sure it is secure, not bent or damaged. Check the cover and paper element seals. Damaged components could allow unfiltered air into engine causing premature wear and failure.
- Install the oiled, foam pre-cleaner around the paper filter element.
- Install the air filter, air filter cover and wing nut. The wing nut must be finger tightened 1/2 to 1 full turn after the nut contacts cover. **DO NOT** overtighten.
- Install the engine housing cover.
- Lower the bucket.



Engine Oil Level Check

- ALWAYS check the engine oil dipstick before using the buggy. At a minimum check engine oil once per day. Follow the Maintenance and Lubrication Chart contained herein.
- ALWAYS use a good quality engine oil.
- The engine oil fill is the same as the oil dipstick hole and is located on the engine block opposite the crankcase drain hose and plug.
- Use oil grades appropriate to the surrounding temperature range as shown below. See **GRADE OF OIL CHART** under **CHANGING ENGINE OIL** section below.
- Remove engine oil dipstick to access oil fill hole. To fill engine with oil use a long funnel to avoid spilling or use an oil can filled with the proper weight small engine oil and squirt oil directly into fill hole. Check oil level with dipstick. Fill the crank case to the full mark on the dipstick. **DO NOT** overfill.
- Replace dipstick.

Change Engine Oil



Important: Engine oil is best drained when the engine is warm. Warm oil flows freely and carries away more impurities than cold oil.

Note: Change engine oil every **25 hours** of operation. On a new engine, change oil after the first **5 hours** of operation.

Note: Buggy must be on a level surface when changing and checking oil.

- Apply and lock the parking brake and block each side of the track.

Note: Viscosities shown in the chart below may be used when the average temperature in your area is within the indicated range.

- SAE 30 is recommended for general, all-temperature use (above 32°F (0°C)).

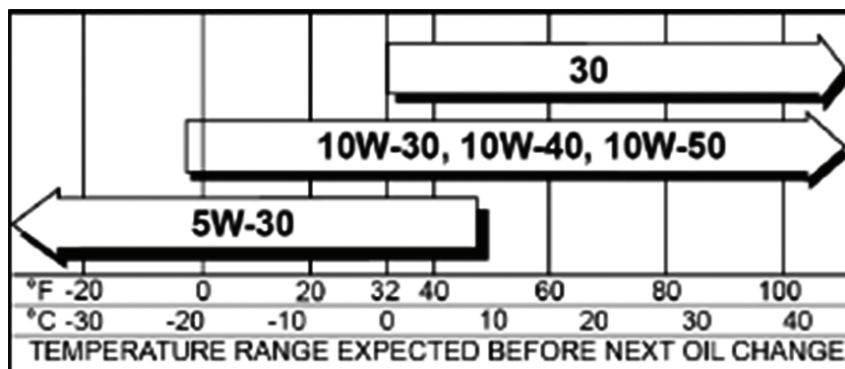

SECTION 3 SERVICE

Maintenance Schedule

Maintenance Schedule					
Item	Daily	Weekly	Monthly	Annually	100 Hours
Check external hardware	✓				
Check hydraulic oil level	✓				
Check hydraulic fittings and hoses	✓				
Apply grease to track rollers	✓				
Apply grease to bucket hinge			✓		
Check all operational controls	✓				
Tighten all bolts and nuts.			✓		
Grease steering assembly cartridge bearing					
Tighten any loose bolts, nuts, etc					✓
Inspect visually for loose or missing parts	✓				
Wash wet concrete of machine	✓				
Clean fuel sediment bowl		✓			
Inspect battery (fill with water if needed)		✓			
Change transmission oil				✓	
Inspect drive belts			✓		
Inspect all rollers and tracks				✓	
Check all adjustments					✓
Change the engine oil				✓	
Check paper air cleaner element		✓			
Thoroughly clean machine				✓	
Change the hydraulic oil					✓

Filter Replacement

SECTION 3 SERVICE



AIR CLEANER PAPER ELEMENT
PART #: 45 083 02



ENGINE OIL FILTER
PART #: 52 050 02



ENGINE FUEL FILTER
PART #: 24 050 13



HYDRAULIC OIL FILTER
PART #: 046730

SECTION 3 SERVICE

Filter Replacement - cont'd



FILTER MAINTENANCE KIT

Includes air filter, pre-cleaner, oil filter, fuel filter, 10W-30 oil (2-quarts) and 2-spark plugs

Air filter part number 45 083 01

Pre-cleaner part number 45 083 01

Oil filter part number 52 050 02

Fuel filter part number 24 050 13

Spark plug part number 12 132 02

NOTE

The track stretches during its life cycle and needs to be adjusted regularly.

Hoist one side of the machine so that the buggy is parallel to the ground.

Inspect the clearance between the track and the second wheel to be approximately 1/2" [12.7mm]. Adjust the tracks by loosening the lock nuts and tightening the adjustment bolt to the desired dimension. After the desired adjustment has been made, retighten the lock nut.

Lower the machine.

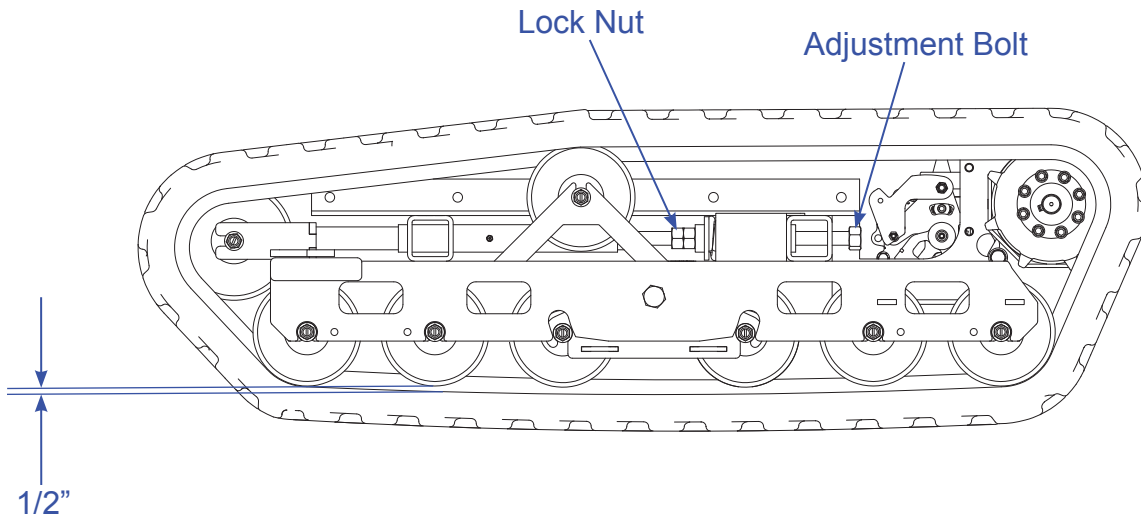

SECTION 3 SERVICE

Troubleshooting

Area	Malfunction	Possible Cause	Corrective Measure	Ref.
Engine	Engine does not start, or is difficult to start	Battery is discharged	- Add battery fluid - Charge the battery - Replace the battery	
		Battery cable is disconnected	- Connect battery cable	
		Blown fuse	- Replace fuse	
		Bad connection or breakage in the wiring	- Contact your AEC dealer	
		Out of fuel	- Fill fuel	
		Air is in fuel	- Contact your AEC dealer	
		Engine fouled	- Wait a while and try starting again	
		Insufficient or wrong oil	- Fill or change oil	
		Dirty or damaged spark plug	- Clean or replace spark plug	
		Contamination in fuel system	- Contact your AEC dealer	
		Parking brake is not engaged	- Engage brake lever into the "lock" position	
		Other (other than above)	- Contact your AEC dealer	
	Engine stalls	Out of fuel	- Fill fuel	
		Cold engine	- Warm up the engine	
		Other (other than above)	- Contact your AEC dealer	
	Engine stops abruptly	Out of fuel	- Fill fuel	
		Piston seizure due to insufficient or bad oil	- Contact your AEC dealer	
		Other (other than above)	- Contact your AEC dealer	
	Engine does not stop	Electrical malfunction	- Contact your AEC dealer	
		Other (other than above)	- Contact your AEC dealer	
	Idling is not stable	Insufficient intake air (clogged air cleaner)	- Clean or replace the air cleaner	
		Other (other than above)	- Contact your AEC dealer	
	Poor power or acceleration	Bad fuel	- Change fuel	
		Wrong oil (improper viscosity)	- Change to suitable oil	
		Accelerator (throttle) is not properly adjusted	- Contact your AEC dealer	
		Insufficient intake air (clogged air cleaner)	- Clean or replace the air cleaner	
		Excessive load	- Reduce load	
		Loose drive belt	- Adjust	
	Irregular noise or vibration from or around the engine		- Contact your AEC dealer	
			- Contact your AEC dealer	
	Excessive oil consumption		- Contact your AEC dealer	
	Engine overheats	Insufficient amount of engine oil	- Fill oil	
		Cooling fan is clogged or blocked	- Clean	
Other (other than above)		- Contact your AEC dealer		
Excessive fuel consumption	Clogged air cleaner	- Clean or replace air cleaner		
	Other (other than above)	- Contact your AEC dealer		

Troubleshooting - cont'd

SECTION 3 SERVICE

Area	Malfunction	Possible Cause	Corrective Measure	Ref.
Engine	Black smoke comes out of exhaust	Bad fuel	- Change fuel	
		Clogged air cleaner	- Clean or replace the air cleaner	
		Choke is not fully open	- Open the choke fully	
		Other (other than above)	- Contact your AEC dealer	
	White or blue smoke comes out of exhaust	Engine oil level is too high	- Adjust the oil level	
	Other (other than above)	- Contact your AEC dealer		
Drive Train	Machine does not move	Parking brake is applied	- Release the parking brake	
		Excessive load	- Reduce load	
		Other (other than above)	- Contact your AEC dealer	
	Irregular noise or heat is observed around the track		- Contact your AEC dealer	
Brake	Brake does not work well	Not properly adjusted	- Adjust	
		Brake is wet with water	- Apply brake a few times to dry	
		Other (other than above)	- Contact your AEC dealer	
Track	Track does not move smoothly	Not properly adjusted	- Adjust	
		Other (other than above)	- Contact your AEC dealer	
Safety Devices	Lamp does not light	Blown bulb	- Replace	
		Blown fuse	- Replace	
		Other (other than above)	- Contact your AEC dealer	
Hydraulic System	Dump does not work	Insufficient or deteriorated hydraulic fluid	- Add or change fluid	
		Loose hydraulics belt	- Adjust	
		Other (other than above)	- Contact your AEC dealer	

SECTION 3 SERVICE

Engine Belt Tension Adjustment

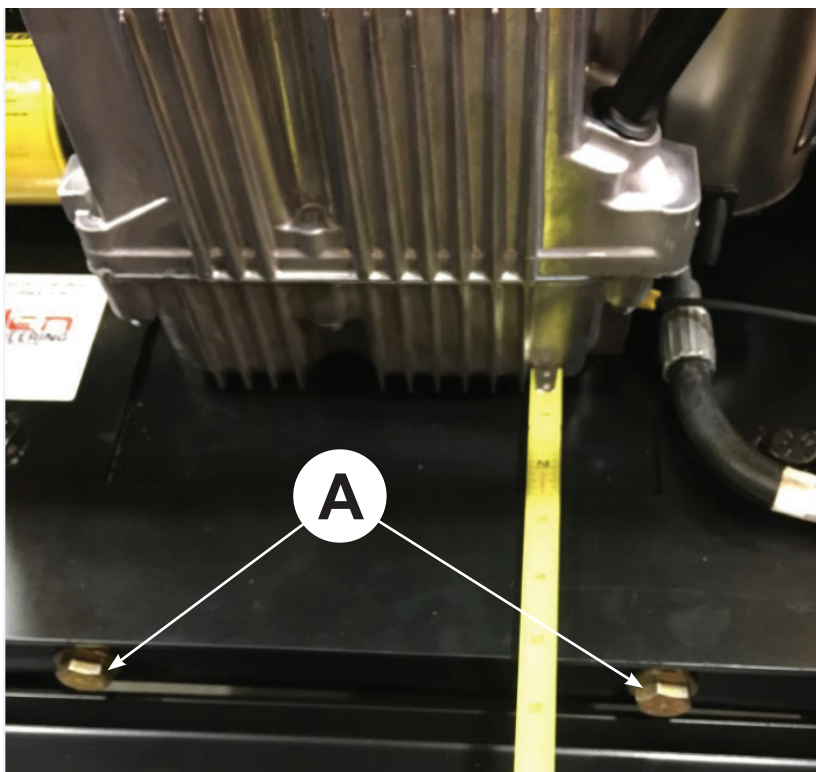

- 1) To tension engine belts use the 2 engine belt tensioning bolts. (A)
- 2) Engine Belt Tensioning Specifications are 2-1/8".

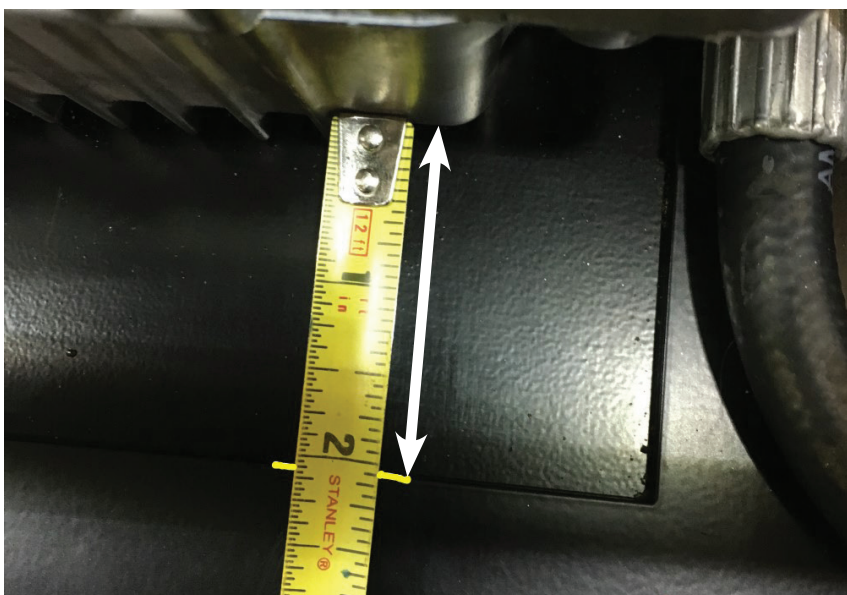

- 3) When tensioning engine belts place a tape measure on the Main Frame as pictured above. The end of the tape measure will rest against the engine block.
- 4) There is a recess in the Main Frame for the Engine plate as indicated in picture above with a yellow line. This is where you will get your tensioning specification of 2 1/8".

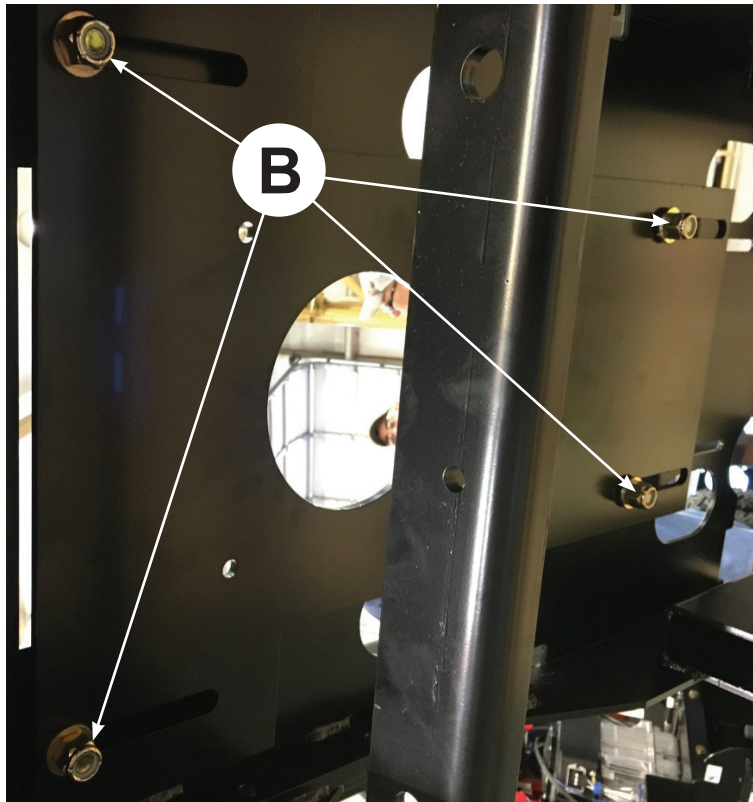

- 5) After setting Engine belt tension to 2-1/8" you will then tighten up the engine plate adjustment bolts (B) at the bottom of the Engine Mount Plate using a 3/4" wrench. After tightening nuts on plate you will then tighten up the Jam nuts on the inside of frame for Belt Tensioning Bolts.
- 6) Belt Tensioning Procedure is complete.
- 7) Reverse Procedure for belt removal.

SECTION 3 SERVICE

Auxillary Belt Tension Adjustment



- 1) Place straight edge on the edge of the framework. Notice the arrows that point to the two half moon cut-outs in the framework, use the cut-outs as a guideline for tensioning the Auxillary Pump.

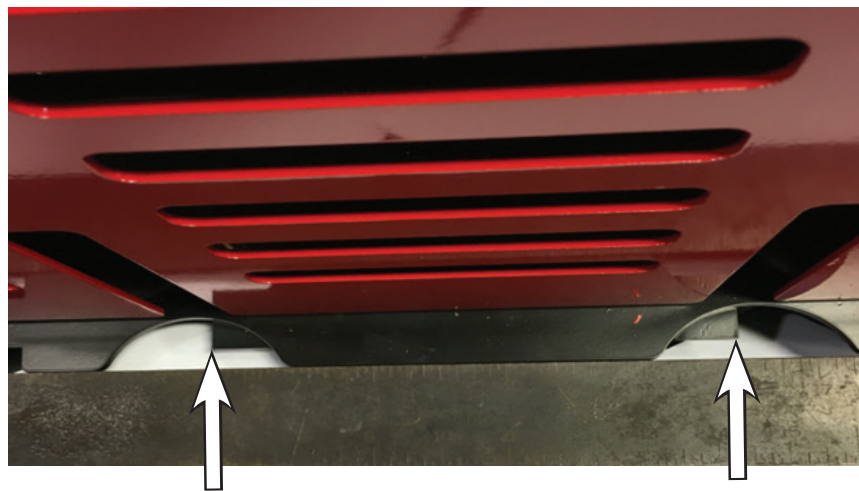

- 2) The arrows in picture above point to the corner edges of the pump mounting plate.



- 3) Place a tape measure against the back side of cut-out and measure $\frac{1}{2}$ " to the corner edge of the pump mounting plate for desired Auxillary Pump belt tension.
- 4) **Auxillary Pump Belt tension must be set before setting Engine / Transmission Drive belt tension.**

SECTION 3 SERVICE

VISIT US!!!



www.alleneng.com

LIKE US!!!



www.facebook.com/AllenEngineering

FOLLOW US!!!



[@alleneng](https://twitter.com/alleneng)

WATCH US!!!



www.youtube.com/AllenMachinery

Section 4
PARTS

SECTION 4 PARTS

Factory Service Information

This section contains the illustrated drawings and parts list for help in identifying and/or ordering replacement parts for your machine. Follow the instructions in the front section of this manual “Ordering Parts” when ordering replacement parts to insure prompt and accurate delivery.

The FRONT and/or REAR orientations are defined from the operator’s view of sitting on machine (SOM).



! NOTE

All set screws have blue (LOC-TITE™) applied at the factory. If set screw is removed or loosened for any reason re-apply blue (LOC-TITE™).



! NOTE

All grease fittings are capped with CAP PLUG GC-5 (AEC PN 015692) to protect the fitting. If cap becomes missing or damaged replace it as soon as possible.



! NOTE

Anti-Seize is applied at the factory to drive line couplings, and moving components. If these parts are disassembled re-apply a light coat of a graphite based anti-seize.

We recommend AEC quality replacement parts, available from the AEC Customer Service Department or your nearest AEC Dealer.

Part numbers are subject to change without notice. Part numbers might be different outside of the United States of America. Use part numbers listed in the applicable parts list table when you place your order. If a part number changes, the AEC Customer Service Department or your nearest AEC dealer will have the latest part number for the replacement part.

Remember when you order replacement parts, you will need your model number and serial number. These are the numbers that you have recorded in the UNIT ID section of this manual. Please order replacement parts by the appropriate part number, not the key number.

This manual contains an illustrated parts list for help in ordering replacement parts for your machine. Follow the instructions below when ordering parts to insure prompt and accurate delivery:

1. All orders for service parts - include the serial number for the machine. Shipment will be delayed if this information is not available.
2. Include correct description and part number from the "PARTS" Section 4.
3. Specify exact shipping instructions, including the preferred routing and complete destination address.
4. DO NOT return parts to AEC without receiving written authorization from AEC. All authorized returns must be shipped pre-paid.
5. When placing an order, please contact the AEC Dealer nearest you.

NOTE

All information, specifications, and illustrations in this manual are subject to change without notice and are based on the latest information at the time of publication.

SECTION 4 PARTS

Track Tensioner and Wheel Assembly Illustration

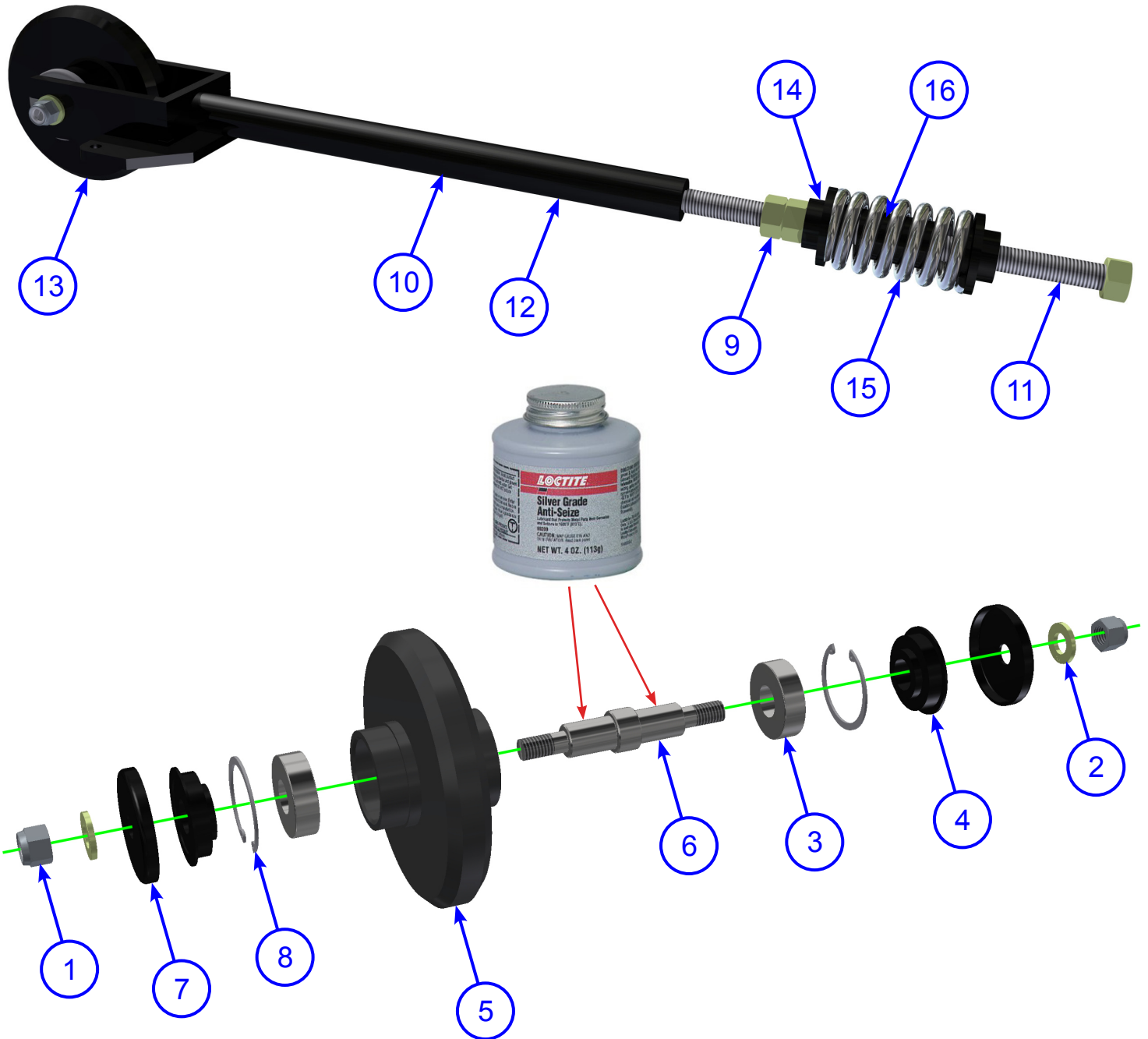

Track Tensioner and Wheel Assembly Parts List

SECTION 4 PARTS

ITEM	PART NO.	DESCRIPTION	QTY
1	011238	FSTN, NUT HEX NYLOK 1/2-13	2
2	011490	FSTN, FW HARDENED 1/2	2
3	056719	BEARING, 6204-2RS C/3	2
4	056720	SEAL, I.S.P. 20 X 47 X 7 A-NBR SEAL	2
5	056728	IDLER WHEEL WMNT	1
6	056729	AXLE F/ IDLER	1
7	056736	SHIELD	2
8	056760	RETAINING RING, INT, 1 13/16	2
9	010112	FSTN, NUT HEX 3/4-10	2
11	056662	IDLER ADJ SCR WMNT	1
12	056733	IDLER ARM WMNT	1
13	056762	IDLER WHEEL ASSEMBLY	1
14	056926	SPRING RETAINER	2
15	054617	IDLER SPRING	1
16	056947	STOP F/ SPRING	1



SECTION 4 PARTS

Track Roller Assembly - 056761 Illustration and Parts List

ITEM	PART NO.	DESCRIPTION	QTY
	056761	ROLLER ASSEMBLY	-
1	011238	FSTN, NUT HEX NYLOK 1/2-13	2
2	011490	FSTN, FW HARDENED 1/2	2
3	056710	AXLE F/ ROLLER	1
4	056718	ROLLER	1
5	056719	BEARING, 6204-2RS C/3	2
6	056720	SEAL, I.S.P. 20 X 47 X 7 A-NBR	2
7	056736	SHIELD	2
8	056760	RETAINING RING, INT, 1 13/16	2

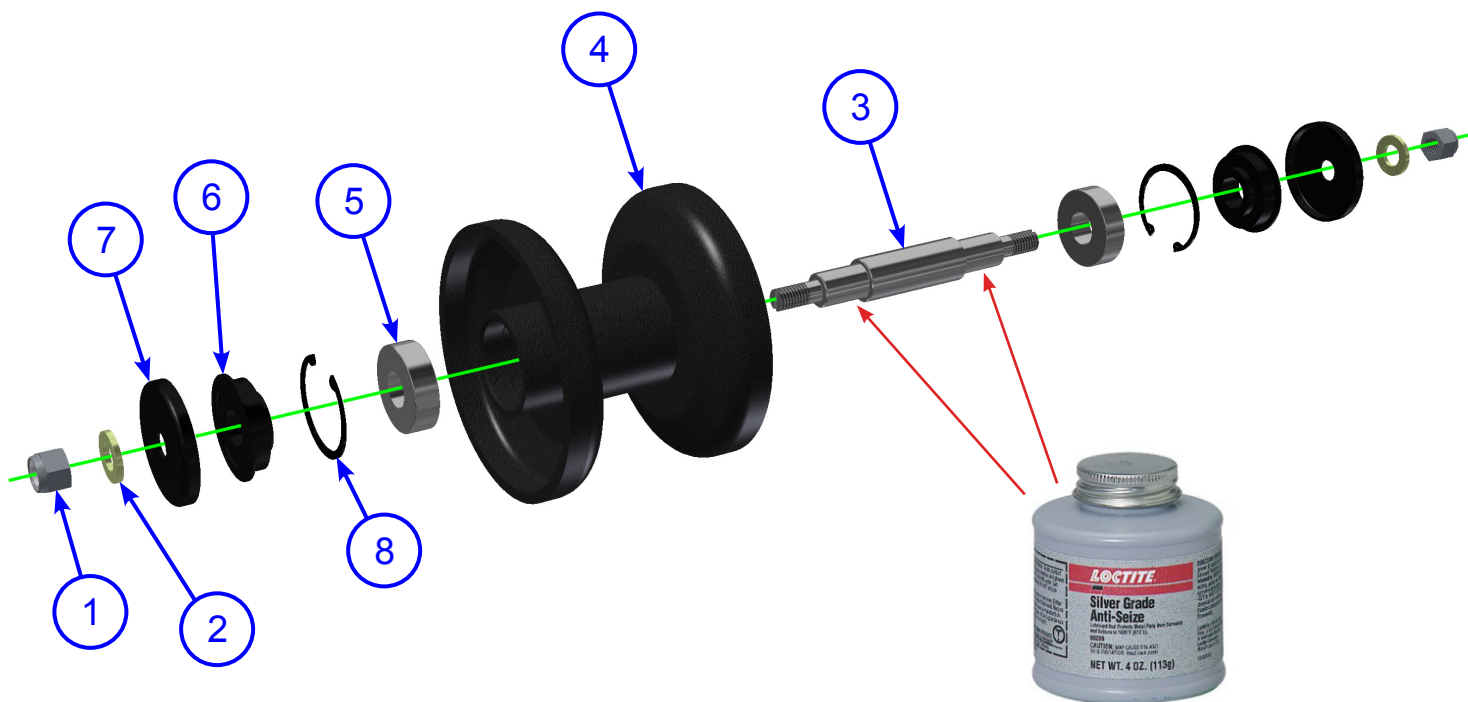

Track Bogey Assembly Illustration and Parts List

SECTION 4 PARTS

ITEM	PART NO.	DESCRIPTION	QTY
1	010513	FITTING, 1/4-28 STR GREASE	1
2	056632	IDLER BOGEY	1
3	056761	ROLLER ASSEMBLY	2



! NOTE

Use Mobilith SHC220
or equivalent on all
grease fittings.

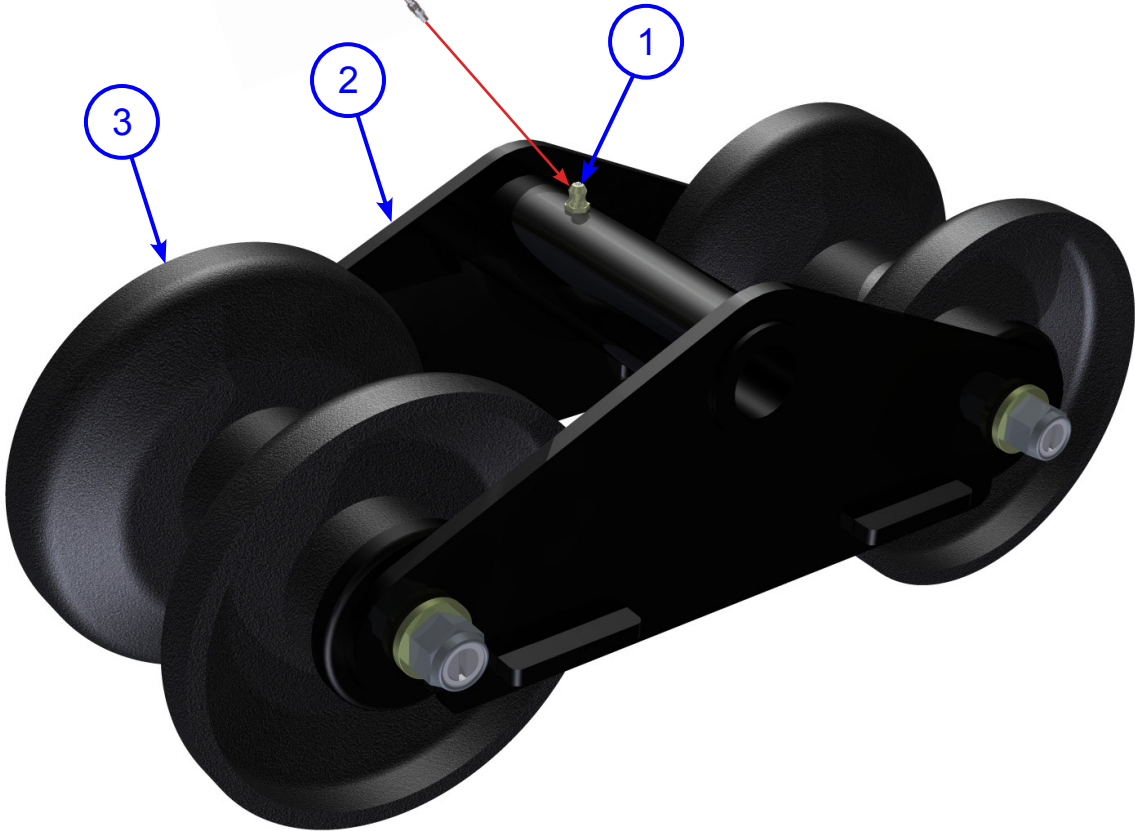

SECTION 4 PARTS

Left Track Assembly - 056674 Illustration

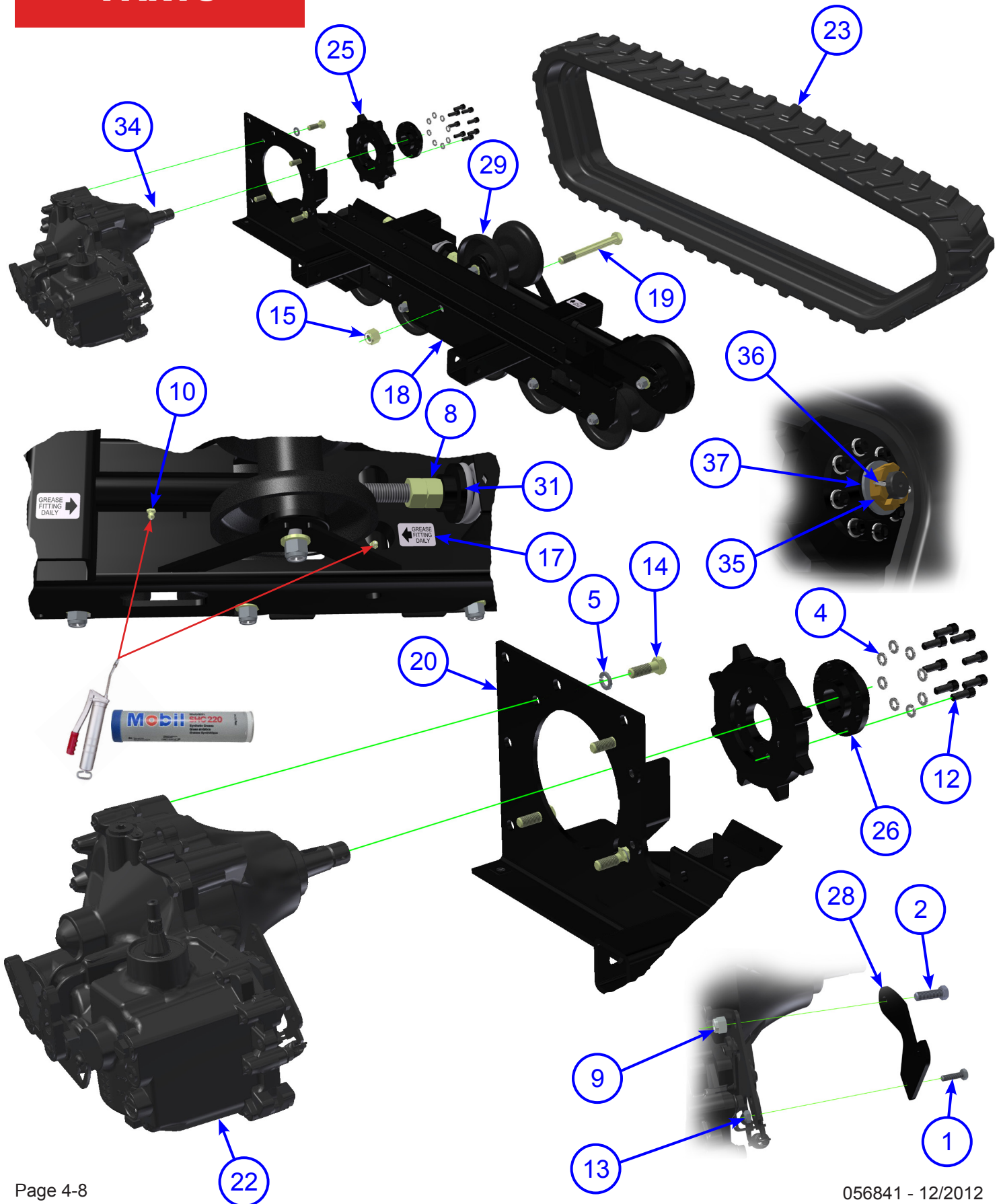

Left Track Assembly - 056674 Parts List

SECTION 4 PARTS

ITEM	PART #	DESCRIPTION	QTY
1	010003	FSTN, HHCS 1/4-20 X 1	1
2	010037	FSTN, HHCS 3/8-16 X 1-1/4 GR 5	1
4	010091	FSTN, LW 3/8	8
5	010093	FSTN, LW 1/2	4
8	010112	FSTN, NUT HEX 3/4-10	2
9	010464	FSTN, NUT NYLOK 3/8-16	1
10	010513	FITTING, 1/4-28 STR GREASE	1
11	011490	FSTN, FW HARDENED 1/2	1
12	015884	SCREW, 3/8-16x1 SCKT CAP	8
13	020542	FSTN, NUT STOVER LOCK 1/4-20	1
14	037798	FSTN, HHCS 1/2-13 X 1 1/2 GR8	4
15	049351	FSTN, NUT 3/4-10 GR 8 NYLOCK HEX	1
16	052802	DECAL, LEFT ARROW GREASE FITTING	1
17	052803	DECAL, RIGHT ARROW GREASE FITTING	1
18	056633	BOGEY ASSEMBLY	1
19	056636	FSTN, HHCS 3/4-10 X 7 1/2" GRADE 8 ZINC	1
20	056652	TRACK FRAME, LH	1
21	056662	IDLER ADJ SCR WMNT	1
22	056675	TRANSMISSION LH HYDROSTATIC	1
23	056676	RUBBER TRACK, 180X72X42	1
24	056733	IDLER ARM WMNT	1
25	056738	SPROCKET	1
26	056739	HUB F/ SPROCKET	1
27	056741	SPANNER TUBE	1
28	056743	ACTUATION ARM	1
29	056761	ROLLER ASSEMBLY	5
30	056762	IDLER WHEEL ASSEMBLY	1
31	056926	SPRING RETAINER	2
32	056937	COMP SPRING, 4"	1
33	056947	STOP F/ SPRING	1
34	059523	KEY, WOODRUFF, 5/16 X 1	1
35	42103-64	FSTN, NUT 1"-20 CASTLE	1
36	42113-05	PIN, COTTER 1/8 x 1-1/2	1
37	010088	FSTN, FW 1	1

SECTION 4 PARTS

Right Track Assembly - 056677 Illustration

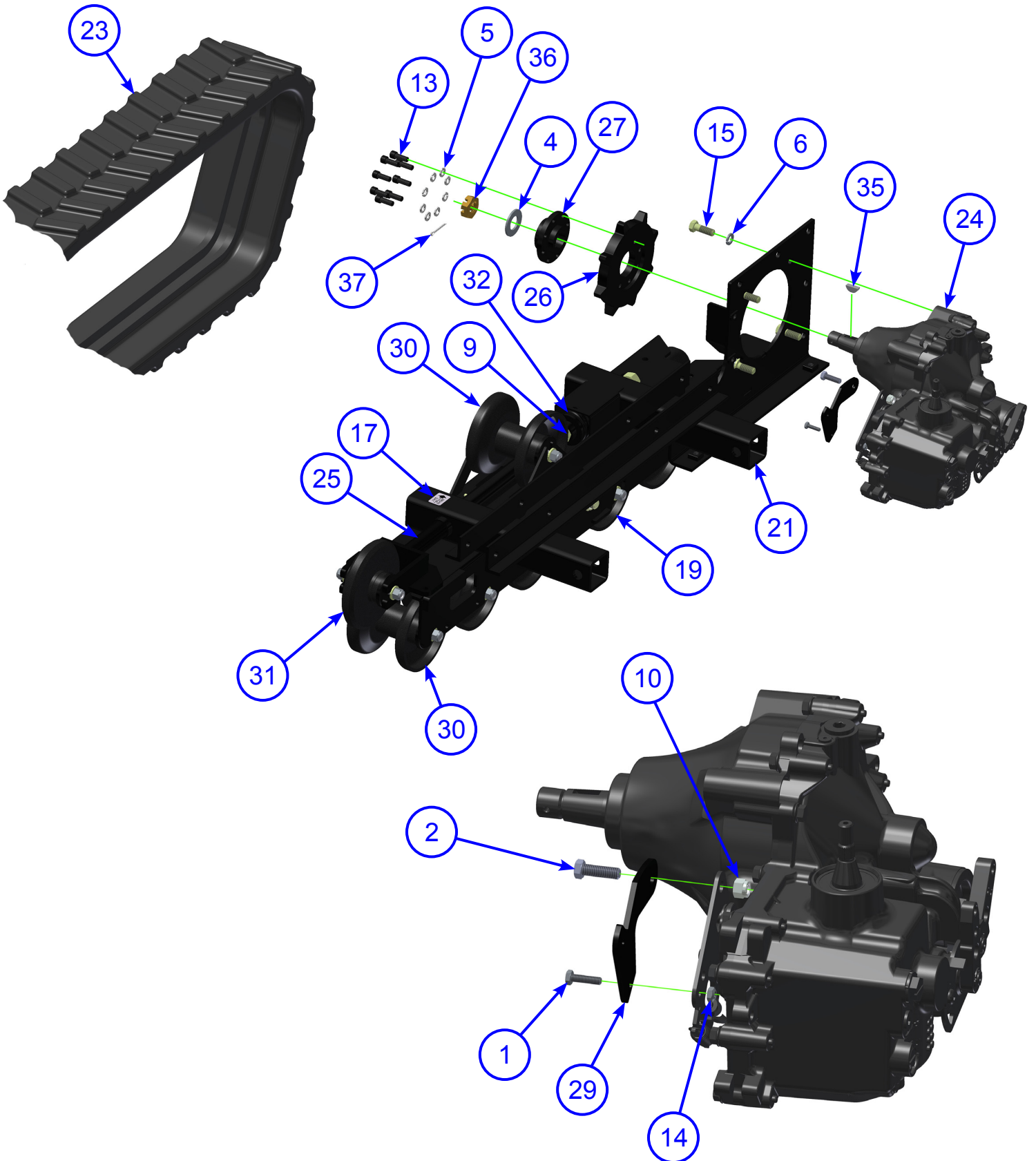

Right Track Assembly - 056677 Parts List

SECTION 4 PARTS

ITEM	PART #	DESCRIPTION	QTY
1	010003	FSTN, HHCS 1/4-20 X 1	1
2	010037	FSTN, HHCS 3/8-16 X 1-1/4 GR 5	1
4	010088	FSTN, FW 1"	1
5	010091	FSTN, LW 3/8	8
8	010102	FSTN, NUT HEX 3/8-16	1
9	010112	FSTN, NUT HEX 3/4-10	2
10	010464	FSTN, NUT NYLOK 3/8-16	1
11	010513	FITTING, 1/4-28 STR GREASE	1
12	011490	FSTN, FW HARDENED 1/2	1
13	015884	SCREW, 3/8-16x1 SCKT CAP	8
14	020542	FSTN, NUT STOVER LOCK 1/4-20	1
15	037798	FSTN, HHCS 1/2-13 X 1 1/2 GR8	4
16	049351	FSTN, NUT 3/4-10 GR 8 NYLOCK HEX	1
17	052802	DECAL, LEFT ARROW GREASE FITTING	1
18	052803	DECAL, RIGHT ARROW GREASE FITTING	1
19	056633	BOGEY ASSEMBLY	1
20	056636	FSTN, HHCS 3/4-10 X 7 1/2" GRADE 8 ZINC	1
21	056654	TRACK HSNB WMNT, RH	1
22	056662	IDLER ADJ SCR WMNT	1
23	056676	RUBBER TRACK, 180X72X42	1
24	056678	TRANSMISSION RH HYDROSTATIC	1
25	056733	IDLER ARM WMNT	1
26	056738	SPROCKET	1
27	056739	HUB F/ SPROCKET	1
28	056741	SPANNER TUBE	1
29	056743	ACTUATION ARM	1
30	056761	ROLLER ASSEMBLY	5
31	056762	IDLER WHEEL ASSEMBLY	1
32	056926	SPRING RETAINER	2
33	056937	COMP SPRING, 4"	1
34	056947	STOP F/ SPRING	1
35	059523	KEY, WOODRUFF, 5/16 X 1	1
36	42103-64	FSTN, NUT 1"-20 CASTLE	1
37	42113-05	PIN, COTTER 1/8 x 1-1/2	1

SECTION 4 PARTS

Lever Assembly Illustration

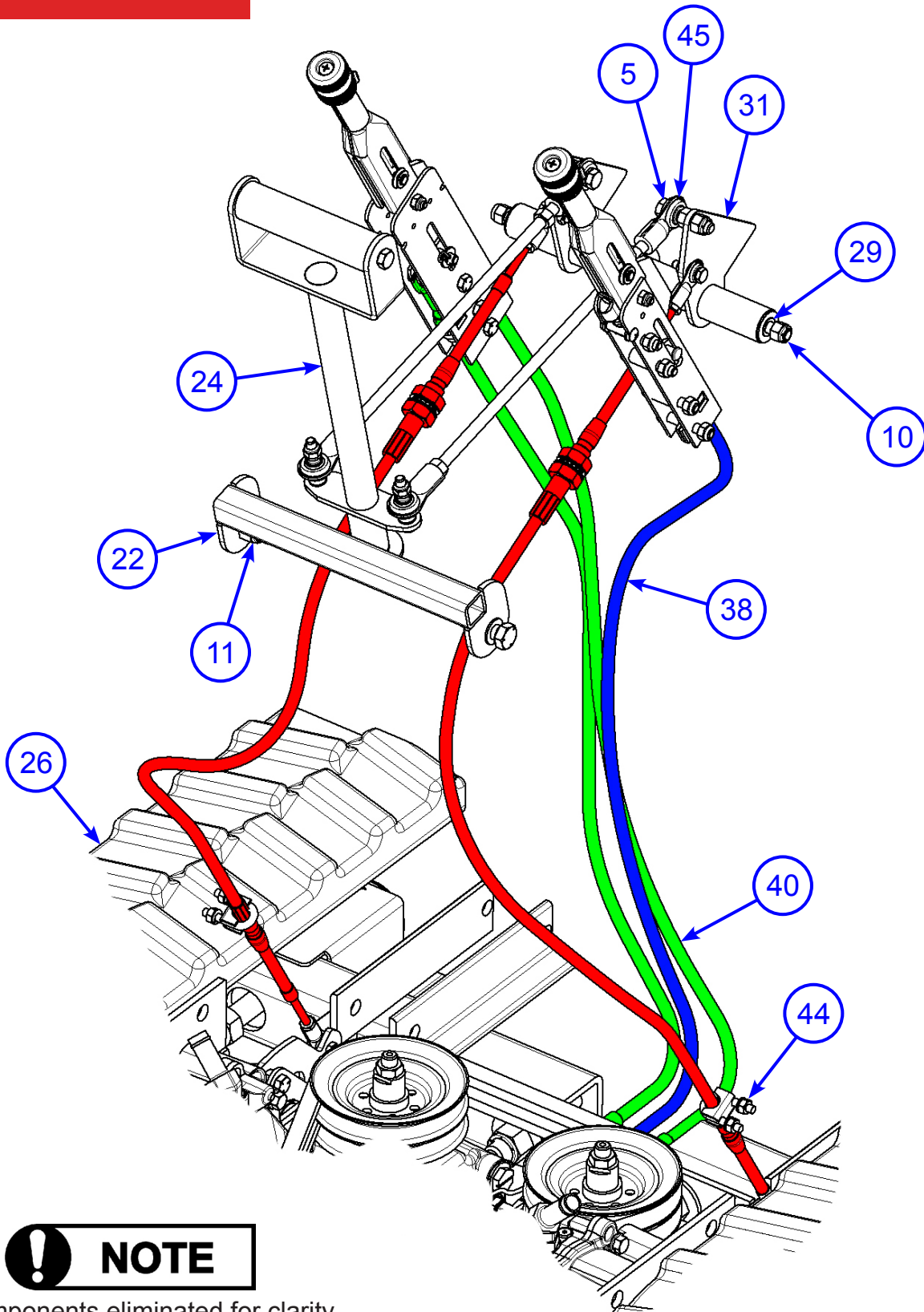

NOTE

Components eliminated for clarity.

Lever Assembly Parts List

SECTION 4 PARTS

ITEM	PART #	DESCRIPTION	QTY
1	010003	FSTN, HHCS 1/4-20 X 1	4
2	010023	FSTN, HHCS 5/16-18 X 1-3/4	7
3	010024	FSTN, HHCS 5/16-18 X 2 GR 5	2
4	010035	FSTN, HHCS 3/8-16 X 3/4	2
5	010039	FSTN, HHCS 3/8-16 X 1 3/4" LONG GR5	2
6	010069	FSTN, HHCS 1/2-13 X 1-1/2	2
7	010087	FSTN, FW 3/4	1
8	010102	FSTN, NUT HEX 3/8-16	2
9	010103	FSTN, NUT HEX 3/8-16	5
10	010464	FSTN, NUT NYLOK 3/8-16	5
11	011238	FSTN, NUT HEX NYLOK 1/2-13	2
12	012612	FSTN, NUT HEX NYLOCK 5/16-18	9
13	012982	FSTN, FW 5/8" ZINC PLATED	1
14	017751	FSTN, FW HARD A325 3/8 (p)	2
15	020542	FSTN, NUT STOVER LOCK 1/4-20	2
16	021368	SCR, 3/8-24X1 HEXHD CAP, GR8	1
17	026447	NUT, 3/4-10 SELFLOCK THIN HEX	1
18	029671	FSTN, NUT HEX 1/4-20 NYLOC	2
19	040488	HHCS, 3/8-16 X 6 1/2	1
20	048929	BEARING, Ø3/4 ID PLASTIC FLANGE	2
21	056389	SHOULDER SPACER, 6294K444	2
22	056395	PIVOT WMNT F/STEERING	1
23	056407	HANDLE F/ STEERING	1
24	056408	STEERING HANDLE WMNT	1
25	056656	FRAME WMNT	1
26	056691	UNDERCARRIAGE ASSEMBLY	1
27	056707	REAR PANEL, LOWER	1
28	056711	NYLON BEARING 6389K621	4
29	056712	SPANNER TUBE	1
30	056713	3/8-16 ALL THREAD, 11 1/2"	1
31	056716	BELL CRANK WMNT	2
32	056735	THREADED ROD F/ STEERING	2
33	056744	HSNG WMNT F/ STEERING	1
34	056751	BRAKE CONTROL BRKT	1
35	056752	BACK PANEL, UPPER	1
36	056754	COMPRESSION SPRING, 3" , 9657k437	1
37	056755	BRAKE SPRING BRKT	1
38	056763	BRAKE CABLE, TRACK BUGGY	1
39	056764	BRAKE LEVER W/ SWITCH, TRACK BUGGY	1
40	056765	OD CABLE, TRACK BUGGY	2
41	056766	HI-LO LEVER, TRACK BUGGY	1
42	056768	STEERING CABLE, TRACK BUGGY	2
44	056769	CABLE CLAMP	2
45	056770	BALL JOINT 3/8"	4
46	056771	BALL JOINT, 1/4"	2
47	056780	CABINET SIDE WMNT	2
48	056874	FOAM HANDLE GRIP	1
49	056877	SPACER	4
50	059516	COUPLING NUT, 3/8-24 X 1 3/4	1

SECTION 4 PARTS

Lever Assembly - cont'd Illustration

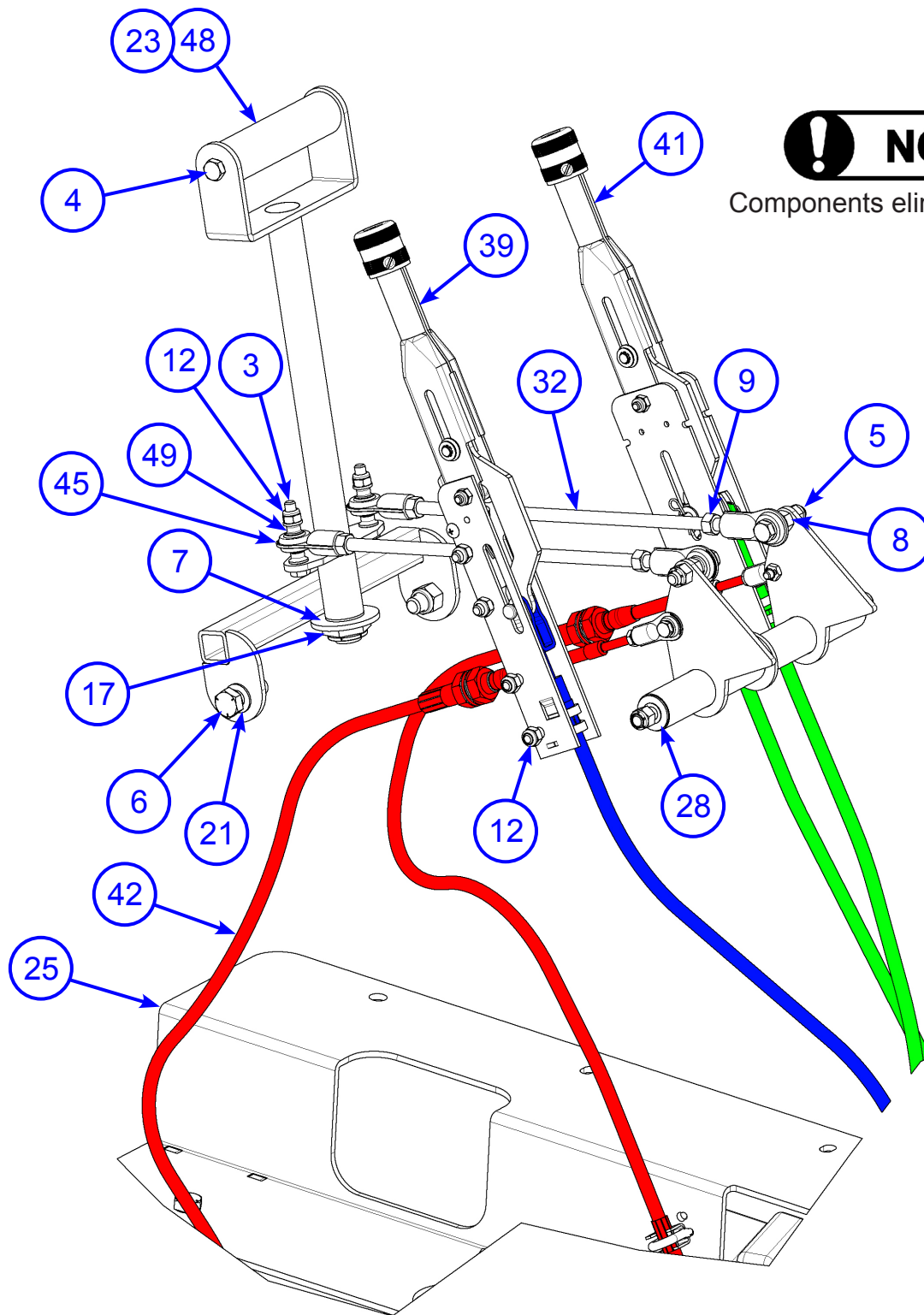

NOTE

Components eliminated for clarity.

Lever Assembly - cont'd Parts List

SECTION 4 PARTS

ITEM	PART #	DESCRIPTION	QTY
1	010003	FSTN, HHCS 1/4-20 X 1	4
2	010023	FSTN, HHCS 5/16-18 X 1-3/4	7
3	010024	FSTN, HHCS 5/16-18 X 2 GR 5	2
4	010035	FSTN, HHCS 3/8-16 X 3/4	2
5	010039	FSTN, HHCS 3/8-16 X 1 3/4" LONG GR5	2
6	010069	FSTN, HHCS 1/2-13 X 1-1/2	2
7	010087	FSTN, FW 3/4	1
8	010102	FSTN, NUT HEX 3/8-16	2
9	010103	FSTN, NUT HEX 3/8-16	5
10	010464	FSTN, NUT NYLOK 3/8-16	5
11	011238	FSTN, NUT HEX NYLOK 1/2-13	2
12	012612	FSTN, NUT HEX NYLOCK 5/16-18	9
13	012982	FSTN, FW 5/8" ZINC PLATED	1
14	017751	FSTN, FW HARD A325 3/8 (p)	2
15	020542	FSTN, NUT STOVER LOCK 1/4-20	2
16	021368	SCR, 3/8-24X1 HEXHD CAP, GR8	1
17	026447	NUT, 3/4-10 SELFLOCK THIN HEX	1
18	029671	FSTN, NUT HEX 1/4-20 NYLOC	2
19	040488	HHCS, 3/8-16 X 6 1/2	1
20	048929	BEARING, Ø3/4 ID PLASTIC FLANGE	2
21	056389	SHOULDER SPACER, 6294K444	2
22	056395	PIVOT WMNT F/STEERING	1
23	056407	HANDLE F/ STEERING	1
24	056408	STEERING HANDLE WMNT	1
25	056656	FRAME WMNT	1
26	056691	UNDERCARRIAGE ASSEMBLY	1
27	056707	REAR PANEL, LOWER	1
28	056711	NYLON BEARING 6389K621	4
29	056712	SPANNER TUBE	1
30	056713	3/8-16 ALL THREAD, 11 1/2"	1
31	056716	BELL CRANK WMNT	2
32	056735	THREADED ROD F/ STEERING	2
33	056744	HSNG WMNT F/ STEERING	1
34	056751	BRAKE CONTROL BRKT	1
35	056752	BACK PANEL, UPPER	1
36	056754	COMPRESSION SPRING, 3" , 9657k437	1
37	056755	BRAKE SPRING BRKT	1
38	056763	BRAKE CABLE, TRACK BUGGY	1
39	056764	BRAKE LEVER W/ SWITCH, TRACK BUGGY	1
40	056765	OD CABLE, TRACK BUGGY	2
41	056766	HI-LO LEVER, TRACK BUGGY	1
42	056768	STEERING CABLE, TRACK BUGGY	2
44	056769	CABLE CLAMP	2
45	056770	BALL JOINT 3/8"	4
46	056771	BALL JOINT, 1/4"	2
47	056780	CABINET SIDE WMNT	2
48	056874	FOAM HANDLE GRIP	1
49	056877	SPACER	4
50	059516	COUPLING NUT, 3/8-24 X 1 3/4	1

SECTION 4
PARTS

Lever Assembly - cont'd
Illustration

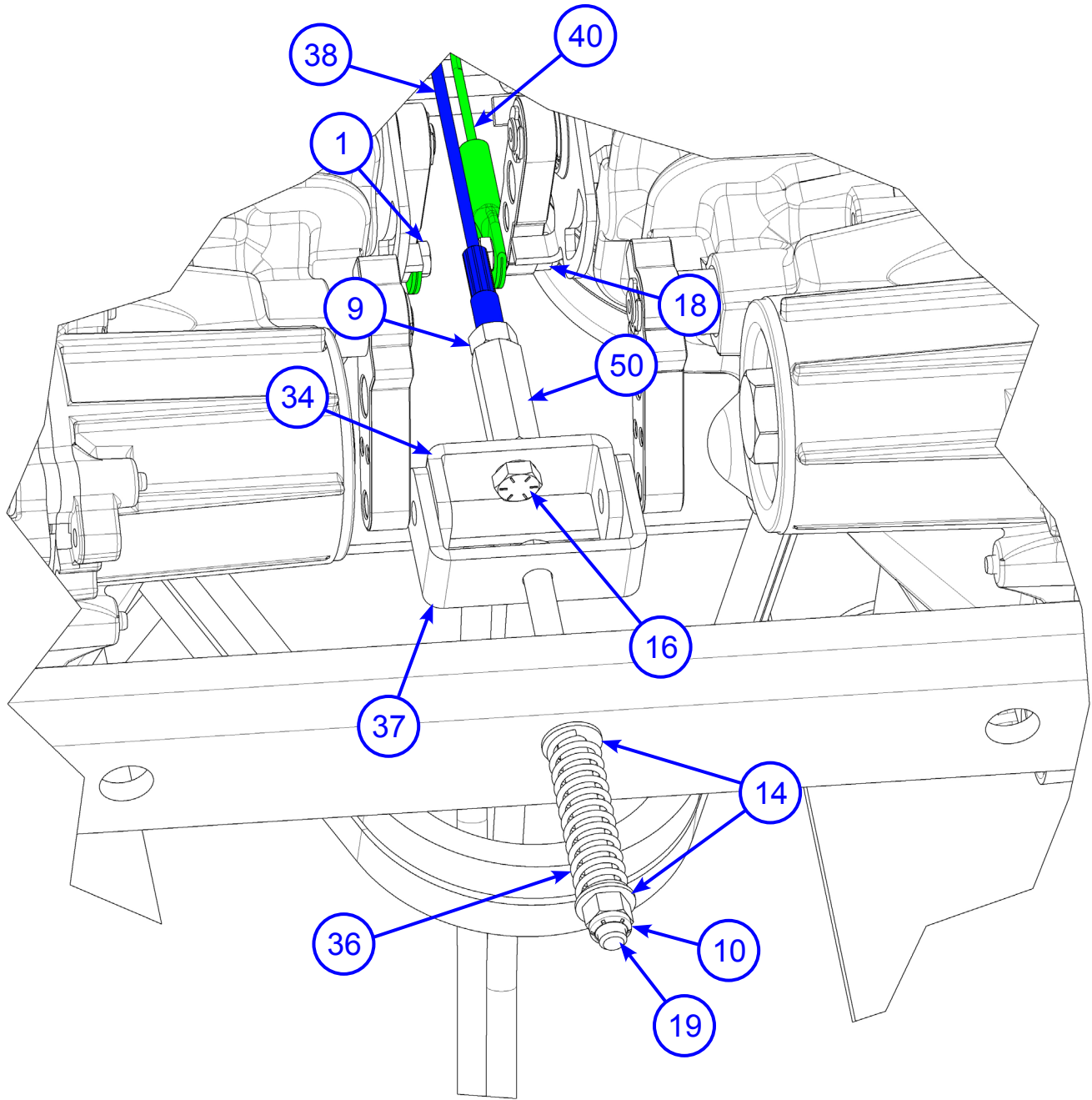

Lever Assembly - cont'd Parts List

SECTION 4 PARTS

ITEM	PART #	DESCRIPTION	QTY
1	010020	FSTN, HHCS 5/16-18 X 1	4
2	010023	FSTN, HHCS 5/16-18 X 1-3/4	7
3	010024	FSTN, HHCS 5/16-18 X 2 GR 5	2
4	010035	FSTN, HHCS 3/8-16 X 3/4	2
5	010039	FSTN, HHCS 3/8-16 X 1 3/4" LONG GR5	2
6	010069	FSTN, HHCS 1/2-13 X 1-1/2	2
7	010087	FSTN, FW 3/4	1
8	010102	FSTN, NUT HEX 3/8-16	2
9	010103	FSTN, NUT HEX 3/8-16	5
10	010464	FSTN, NUT NYLOK 3/8-16	5
11	011238	FSTN, NUT HEX NYLOK 1/2-13	2
12	012612	FSTN, NUT HEX NYLOCK 5/16-18	9
13	012982	FSTN, FW 5/8" ZINC PLATED	1
14	017751	FSTN, FW HARD A325 3/8 (p)	2
15	020542	FSTN, NUT STOVER LOCK 1/4-20	2
16	021368	SCR, 3/8-24X1 HEXHD CAP, GR8	1
17	026447	NUT, 3/4-10 SELFLOCK THIN HEX	1
18	012612	FSTN, NUT HEX NYLOCK 5/16-18	2
19	040488	HHCS, 3/8-16 X 6 1/2	1
20	048929	BEARING, Ø3/4 ID PLASTIC FLANGE	2
21	056389	SHOULDER SPACER, 6294K444	2
22	056395	PIVOT WMNT F/STEERING	1
23	056407	HANDLE F/ STEERING	1
24	056408	STEERING HANDLE WMNT	1
25	056656	FRAME WMNT	1
26	056691	UNDERCARRIAGE ASSEMBLY	1
27	056707	REAR PANEL, LOWER	1
28	056711	NYLON BEARING 6389K621	4
29	056712	SPANNER TUBE	1
30	056713	3/8-16 ALL THREAD, 11 1/2"	1
31	056716	BELL CRANK WMNT	2
32	056735	THREADED ROD F/ STEERING	2
33	056744	HSNG WMNT F/ STEERING	1
34	056751	BRAKE CONTROL BRKT	1
35	056752	BACK PANEL, UPPER	1
36	056754	COMPRESSION SPRING, 3", 9657k437	1
37	056755	BRAKE SPRING BRKT	1
38	056763	BRAKE CABLE, TRACK BUGGY	1
39	056764	BRAKE LEVER W/ SWITCH, TRACK BUGGY	1
40	056765	OD CABLE, TRACK BUGGY	2
41	056766	HI-LO LEVER, TRACK BUGGY	1
42	056768	STEERING CABLE, TRACK BUGGY	2
44	056769	CABLE CLAMP	2
45	056770	BALL JOINT 3/8"	4
46	056771	BALL JOINT, 1/4"	2
47	056780	CABINET SIDE WMNT	2
48	056874	FOAM HANDLE GRIP	1
49	056877	SPACER	4
50	059516	COUPLING NUT, 3/8-24 X 1 3/4	1

SECTION 4
PARTS

Hydraulic Tank Assembly
Illustration

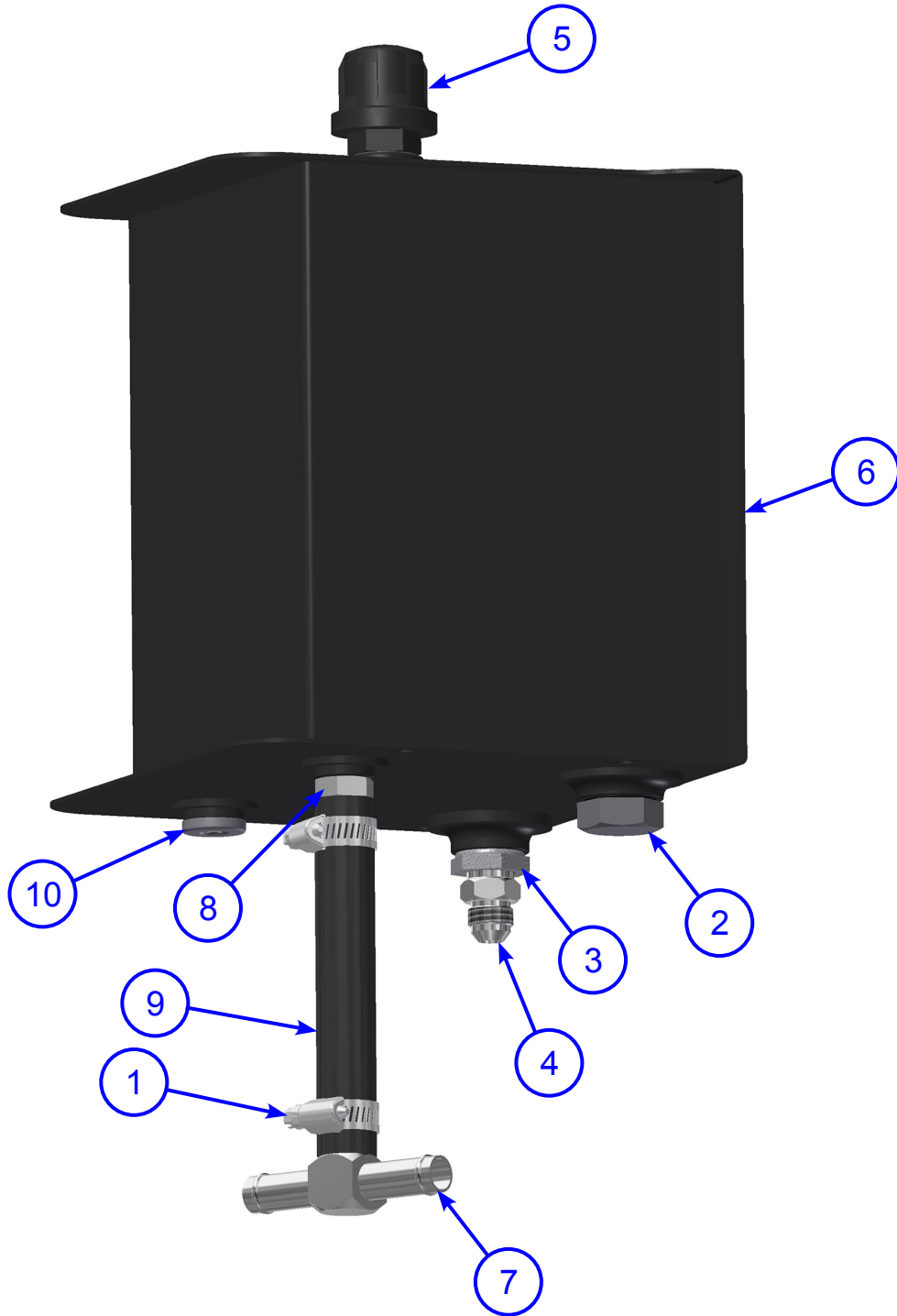

Hydraulic Tank Assembly Parts List

SECTION 4 PARTS

ITEM	PART NO.	DESCRIPTION	QTY
1	038664	#10 HOSE CLAMP	2
2	045948	FITTING, 7574051 MAGNETIC PLUG	1
3	046732	SUCTION STRAINER TMF-02-06	1
4	047518	FTG, F2404-8-8	1
5	056421	FILLER BREATHER	1
6	056758	HYDRAULIC OIL TANK	1
7	052880	FITTING, 4504-10-10-10	1
8	4604-10-8	FITTING, 4604-10-8	1
9	052900	HOSE, HS-TB-9	1
10	052883	PLUG	1

VISIT US!!!



www.alleneng.com

LIKE US!!!



www.facebook.com/AllenEngineering

FOLLOW US!!!



[@alleneng](https://twitter.com/alleneng)

WATCH US!!!



www.youtube.com/AllenMachinery

SECTION 4 PARTS

Hydraulics Illustration

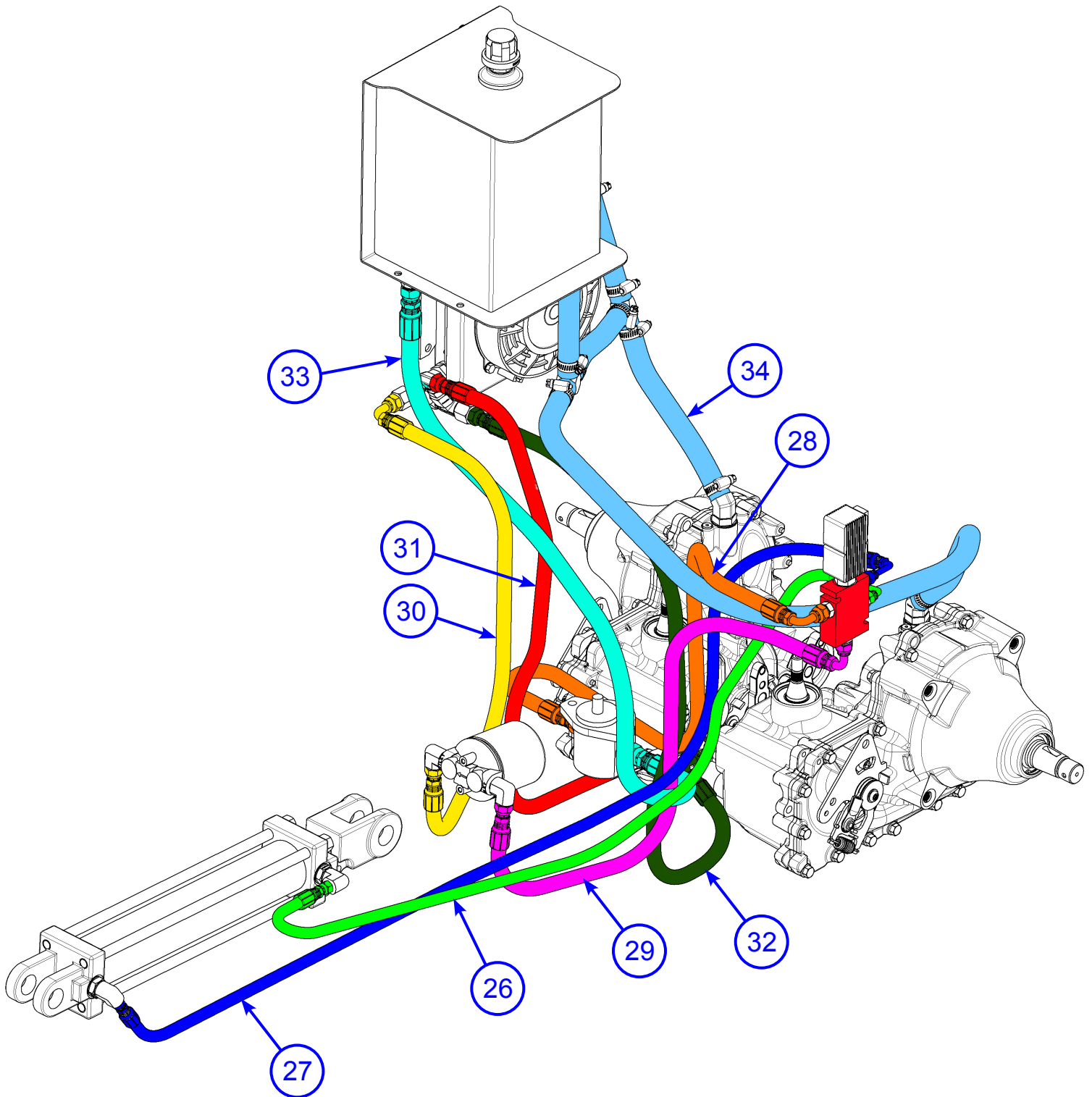

Hydraulics Parts List

SECTION 4 PARTS

ITEM	PART NO.	DESCRIPTION	QTY
1	038664	#10 HOSE CLAMP	8
2	042343	FSTN, SFBHCS 1/4"-20 x 3/4	1
3	045915	FTG, F6400-6-6-O STR JIC-SAE	3
4	045921	FTG, F6400-8-8-O STR JIC-SAE	1
5	045922	FTG, F6400-4-6-O STR JIC-SAE	2
6	045952	FTG, F6801-6-6-NWO 90° ELB	2
7	046350	FTG, F6602-8-8-8-O TEE	2
8	046366	F2406-08-06-0 FLARE-O FITTING	3
9	046729	FILTER HEAD SLF-030	1
10	046730	FILTER ELEMENT SF 6310-18	1
11	048740	FTG., F6801-4-8-NWO	2
12	049024	EXCHANGER, 12 VDC AIR-OIL HEAT	1
13	056675	TRANSMISSION LH HYDROSTATIC	1
14	056678	TRANSMISSION RH HYDROSTATIC	1
15	056915	HYD PUMP, AUX	1
16	056924	VALVE ASSEMBLY FOR TRACK BUGGY	1
17	052884	FITTING, 2501-06-06	2
18	056815	CYLINDER, HYDRAULIC X 3" BORE	1
19	052880	FITTING, 4504-10-10-10	1
20	052886	FITTING, 4601-10-8	1
21	052887	FITTING, 4603-10-10	2
22	052888	FITTING, 6500-06-06	1
23	052889	FITTING, 9002-08-08	1
24	052890	FITTING, 9036-08-08	1
25	052891	WASHER, 9500-08	1
26	052892	4M3K/4G-4FJX/4G-4FJX-90S 54" CYL ROD TO SOL VALVE #3	1
27	052893	4M3K/4G-4FJX/4G-4FJX-90L 72" CYL PISTON TO SOL VALVE #1	1
28	052894	6M3K/6G-6FJX/6G-6GJX-90S 32" AUX PUMP OUTLET TO SOL VALVE #2	1
29	052895	6M3K/6G-6FJX/6G-6GJX-90S 26" FILTER INLET TO SOL VALVE #4	1
30	052896	6M3K/6G-6FJX/6G-6GJX-90S 23" FILTER OUTLET TO COOLER INLET	1
31	052897	6M3K/6G-6FJX/6G-6GJX-90S 26" COOLER INLET TO BOTTOM RH TRANS	1
32	052898	6M3K/6G-6FJX/6G-6GJX-90S 30" COOLER INLET TO BOTTOM LH TRANS	1
33	052899	8M3K/8G-8FJX/8G-8GJX 33" TANK TO AUX PUMP INLET	1
34	052900	1RLA CASE DRAIN LOW PRESSURE CONNECTIONS	80"
35	052901	ENGINE DRAIN HOSE (NOT SHOWN)	1
36	056957	OIL, HYDRAULIC 20W-50	3

SECTION 4 PARTS

Hydraulics - cont'd Illustration

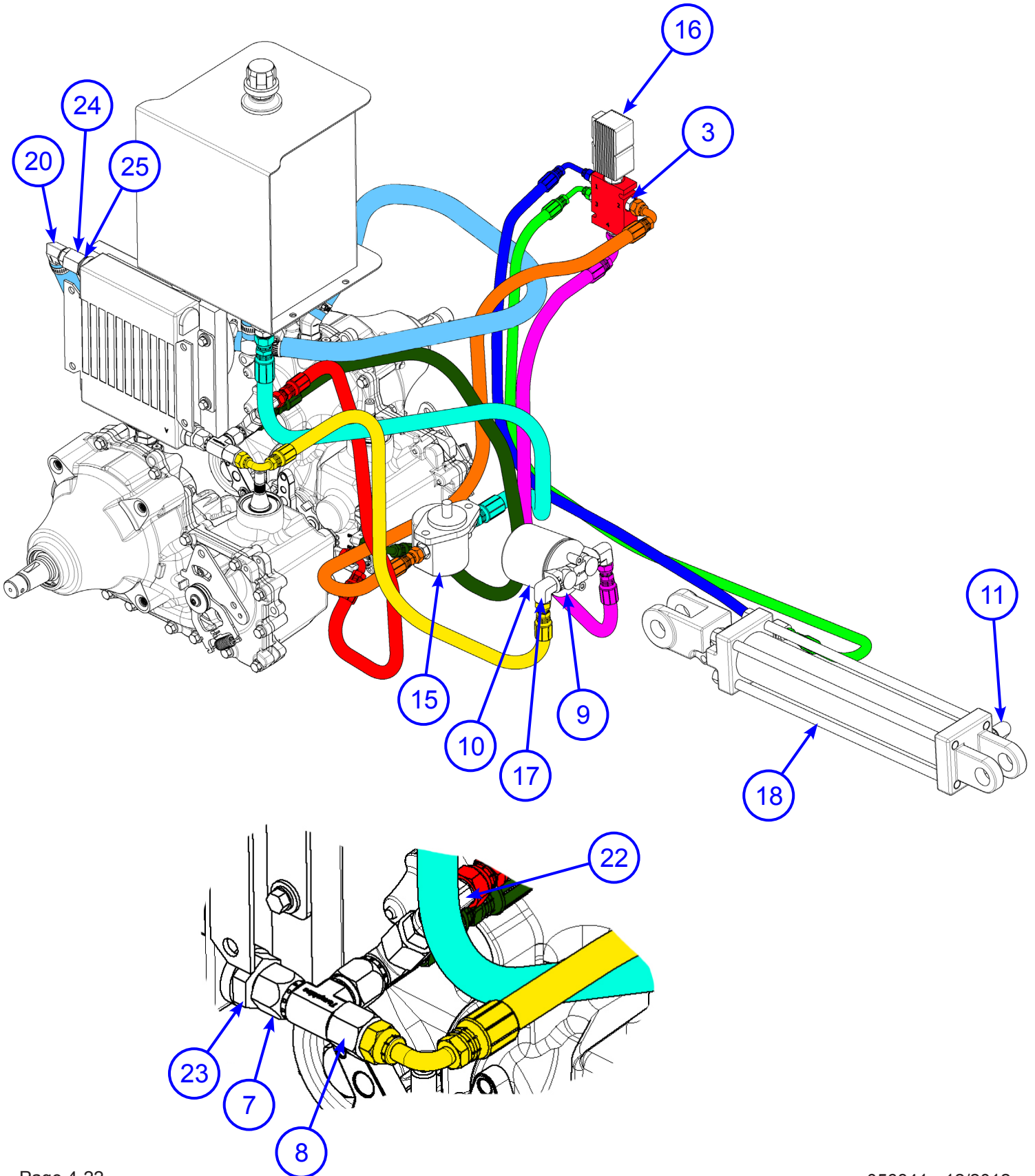

Hydraulics - cont'd Parts List

SECTION 4 PARTS

ITEM	PART NO.	DESCRIPTION	QTY
1	038664	#10 HOSE CLAMP	8
2	042343	FSTN, SFBHCS 1/4"-20 x 3/4	1
3	045915	FTG, F6400-6-6-O STR JIC-SAE	3
4	045921	FTG, F6400-8-8-O STR JIC-SAE	1
5	045922	FTG, F6400-4-6-O STR JIC-SAE	2
6	045952	FTG, F6801-6-6-NWO 90° ELB	2
7	046350	FTG, F6602-8-8-8-O TEE	2
8	046366	F2406-08-06-0 FLARE-O FITTING	3
9	046729	FILTER HEAD SLF-030	1
10	046730	FILTER ELEMENT SF 6310-18	1
11	048740	FTG., F6801-4-8-NWO	2
12	049024	EXCHANGER, 12 VDC AIR-OIL HEAT	1
13	056675	TRANSMISSION LH HYDROSTATIC	1
14	056678	TRANSMISSION RH HYDROSTATIC	1
15	056915	HYD PUMP, AUX	1
16	056924	VALVE ASSEMBLY FOR TRACK BUGGY	1
17	052884	FITTING, 2501-06-06	2
18	056815	CYLINDER, HYDRAULIC X 3" BORE	1
19	052880	FITTING, 4504-10-10-10	1
20	052886	FITTING, 4601-10-8	1
21	052887	FITTING, 4603-10-10	2
22	052888	FITTING, 6500-06-06	1
23	052889	FITTING, 9002-08-08	1
24	052890	FITTING, 9036-08-08	1
25	052891	WASHER, 9500-08	1
26	052892	4M3K/4G-4FJX/4G-4FJX-90S 54" CYL ROD TO SOL VALVE #3	1
27	052893	4M3K/4G-4FJX/4G-4FJX-90L 72" CYL PISTON TO SOL VALVE #1	1
28	052894	6M3K/6G-6FJX/6G-6GJX-90S 32" AUX PUMP OUTLET TO SOL VALVE #2	1
29	052895	6M3K/6G-6FJX/6G-6GJX-90S 26" FILTER INLET TO SOL VALVE #4	1
30	052896	6M3K/6G-6FJX/6G-6GJX-90S 23" FILTER OUTLET TO COOLER INLET	1
31	052897	6M3K/6G-6FJX/6G-6GJX-90S 26" COOLER INLET TO BOTTOM RH TRANS	1
32	052898	6M3K/6G-6FJX/6G-6GJX-90S 30" COOLER INLET TO BOTTOM LH TRANS	1
33	052899	8M3K/8G-8FJX/8G-8GJX 33" TANK TO AUX PUMP INLET	1
34	052900	1RLA CASE DRAIN LOW PRESSURE CONNECTIONS	80"
35	052901	ENGINE DRAIN HOSE (NOT SHOWN)	1
36	056957	OIL, HYDRAULIC 20W-50	3

SECTION 4 PARTS

Hydraulics - cont'd Illustration

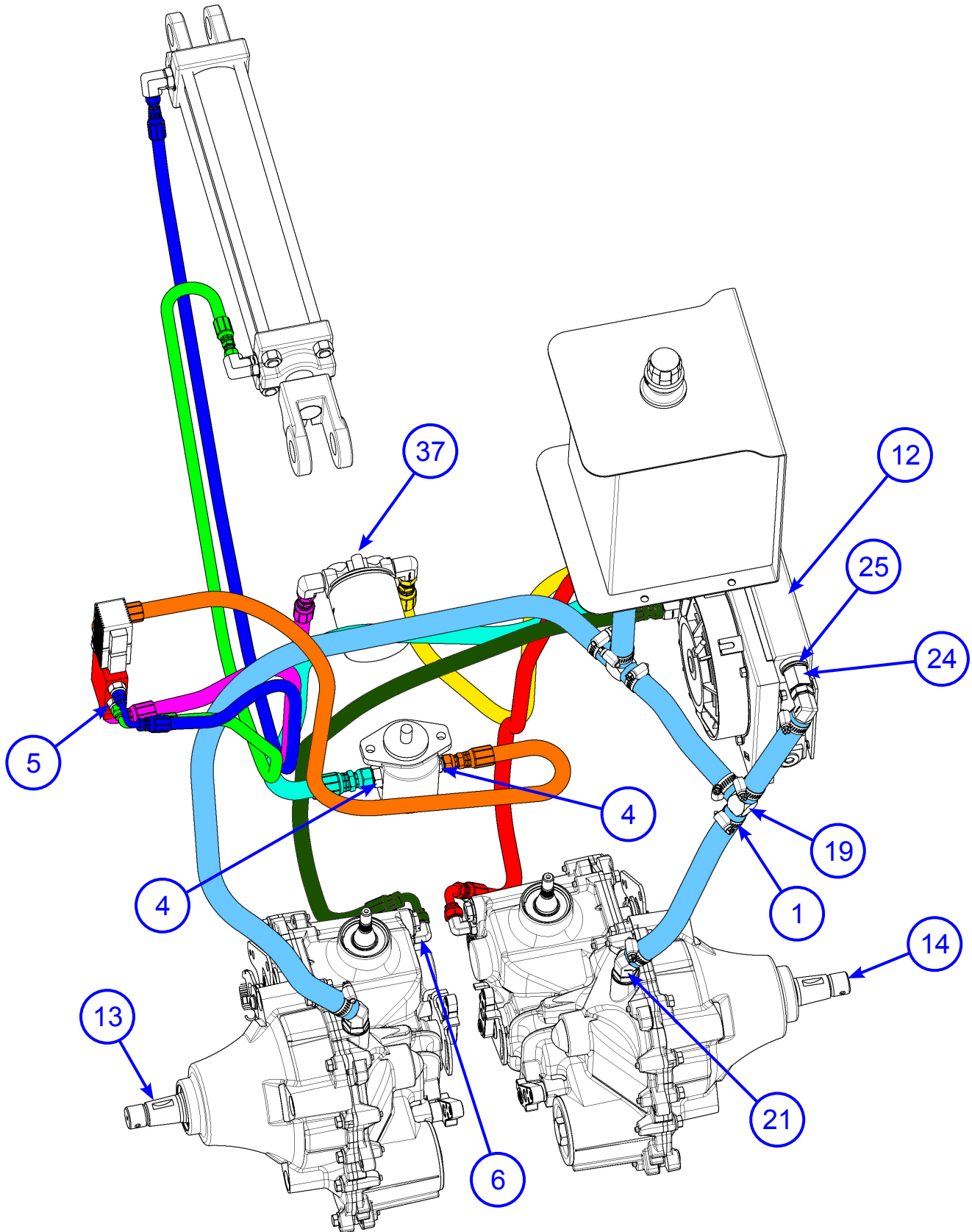

Hydraulics - cont'd Parts List

SECTION 4 PARTS

ITEM	PART NO.	DESCRIPTION	QTY
1	038664	#10 HOSE CLAMP	8
2	042343	FSTN, SFBHCS 1/4"-20 x 3/4	1
3	045915	FTG, F6400-6-6-O STR JIC-SAE	3
4	045921	FTG, F6400-8-8-O STR JIC-SAE	1
5	045922	FTG, F6400-4-6-O STR JIC-SAE	2
6	045952	FTG, F6801-6-6-NWO 90° ELB	2
7	046350	FTG, F6602-8-8-8-O TEE	2
8	046366	F2406-08-06-0 FLARE-O FITTING	3
9	046729	FILTER HEAD SLF-030	1
10	046730	FILTER ELEMENT SF 6310-18	1
11	048740	FTG., F6801-4-8-NWO	2
12	049024	EXCHANGER, 12 VDC AIR-OIL HEAT	1
13	056675	TRANSMISSION LH HYDROSTATIC	1
14	056678	TRANSMISSION RH HYDROSTATIC	1
15	056915	HYD PUMP, AUX	1
16	056924	VALVE ASSEMBLY FOR TRACK BUGGY	1
17	052884	FITTING, 2501-06-06	2
18	056815	CYLINDER, HYDRAULIC X 3" BORE	1
19	052880	FITTING, 4504-10-10-10	1
20	052886	FITTING, 4601-10-8	1
21	052887	FITTING, 4603-10-10	2
22	052888	FITTING, 6500-06-06	1
23	052889	FITTING, 9002-08-08	1
24	052890	FITTING, 9036-08-08	1
25	052891	WASHER, 9500-08	1
26	052892	4M3K/4G-4FJX/4G-4FJX-90S 54" CYL ROD TO SOL VALVE #3	1
27	052893	4M3K/4G-4FJX/4G-4FJX-90L 72" CYL PISTON TO SOL VALVE #1	1
28	052894	6M3K/6G-6FJX/6G-6GJX-90S 32" AUX PUMP OUTLET TO SOL VALVE #2	1
29	052895	6M3K/6G-6FJX/6G-6GJX-90S 26" FILTER INLET TO SOL VALVE #4	1
30	052896	6M3K/6G-6FJX/6G-6GJX-90S 23" FILTER OUTLET TO COOLER INLET	1
31	052897	6M3K/6G-6FJX/6G-6GJX-90S 26" COOLER INLET TO BOTTOM RH TRANS	1
32	052898	6M3K/6G-6FJX/6G-6GJX-90S 30" COOLER INLET TO BOTTOM LH TRANS	1
33	052899	8M3K/8G-8FJX/8G-8GJX 33" TANK TO AUX PUMP INLET	1
34	052900	1RLA CASE DRAIN LOW PRESSURE CONNECTIONS	80"
35	052901	ENGINE DRAIN HOSE (NOT SHOWN)	1
36	056957	OIL, HYDRAULIC 20W-50	3
37	42103-11	FSTN 1/4-20 x 3/4 FSHCS	2

SECTION 4 PARTS

Electrical Schematic

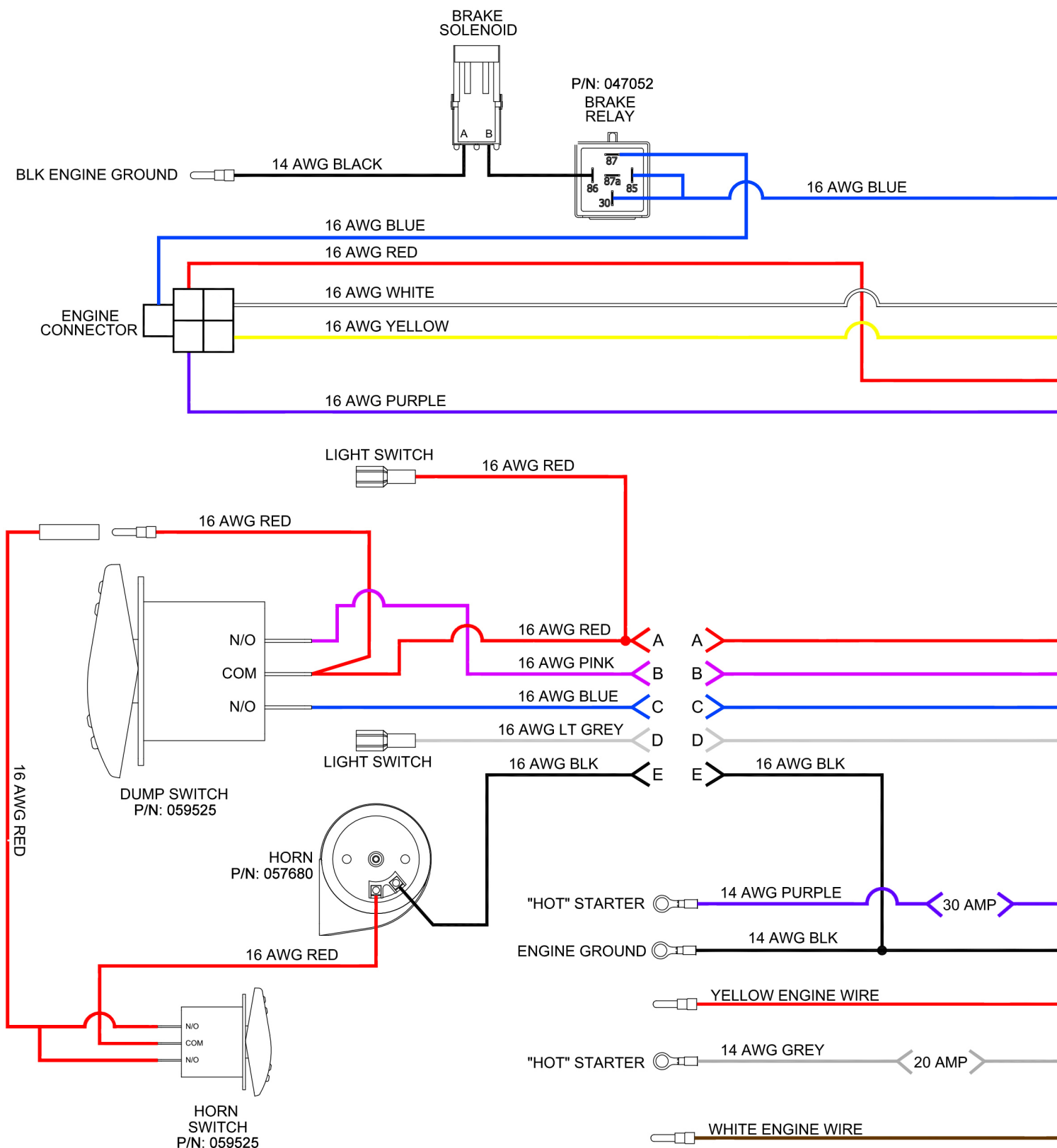

SECTION 4 PARTS

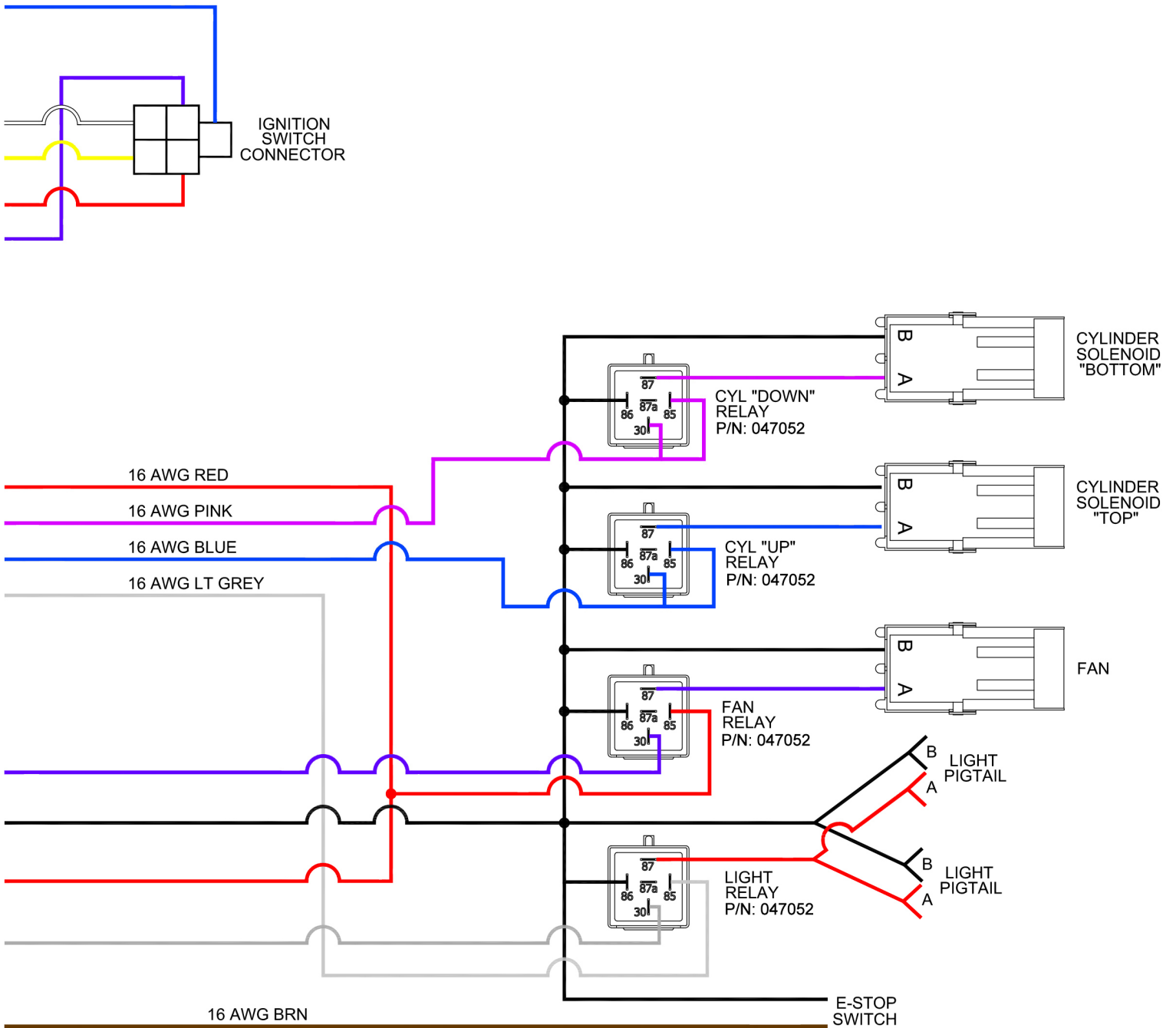

SECTION 4 PARTS

Cabinet Assembly Illustration

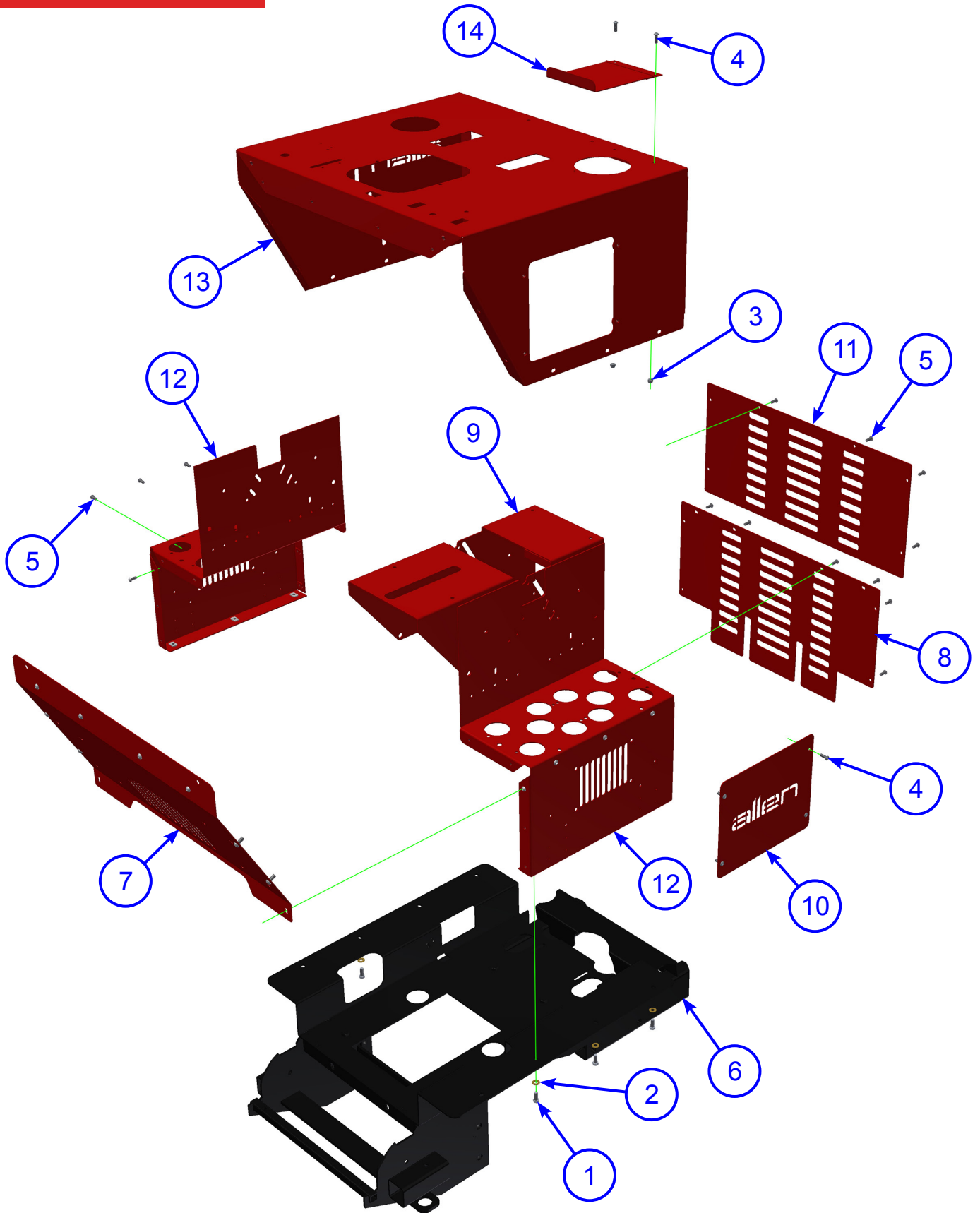

Cabinet Assembly Parts List

SECTION 4 PARTS

ITEM	PART NO.	DESCRIPTION	QTY
1	010036	FSTN, HHCS 3/8-16 X 1	6
2	017751	FSTN, FW HARD A325 3/8 (p)	6
3	029671	FSTN, NUT HEX 1/4-20 NYLOC	2
4	042343	FSTN, SFBHCS 1/4"-20 x 3/4	6
5	042344	FSTN, SFBHCS 5/16"-18 x 3/4	30
6	056656	MAIN FRAME WMNT	1
7	056706	FRONT PANEL	1
8	056707	REAR PANEL, LOWER	1
9	056744	HSNG WMNT F/ STEERING	1
10	056750	COVER PLATE F/ BATTERY	1
11	056752	BACK PANEL, UPPER	1
12	056780	CABINET SIDE WMNT	2
13	056781	TOP COVER WMNT	1
14	056919	DOOR WMNT	1



SECTION 4 PARTS

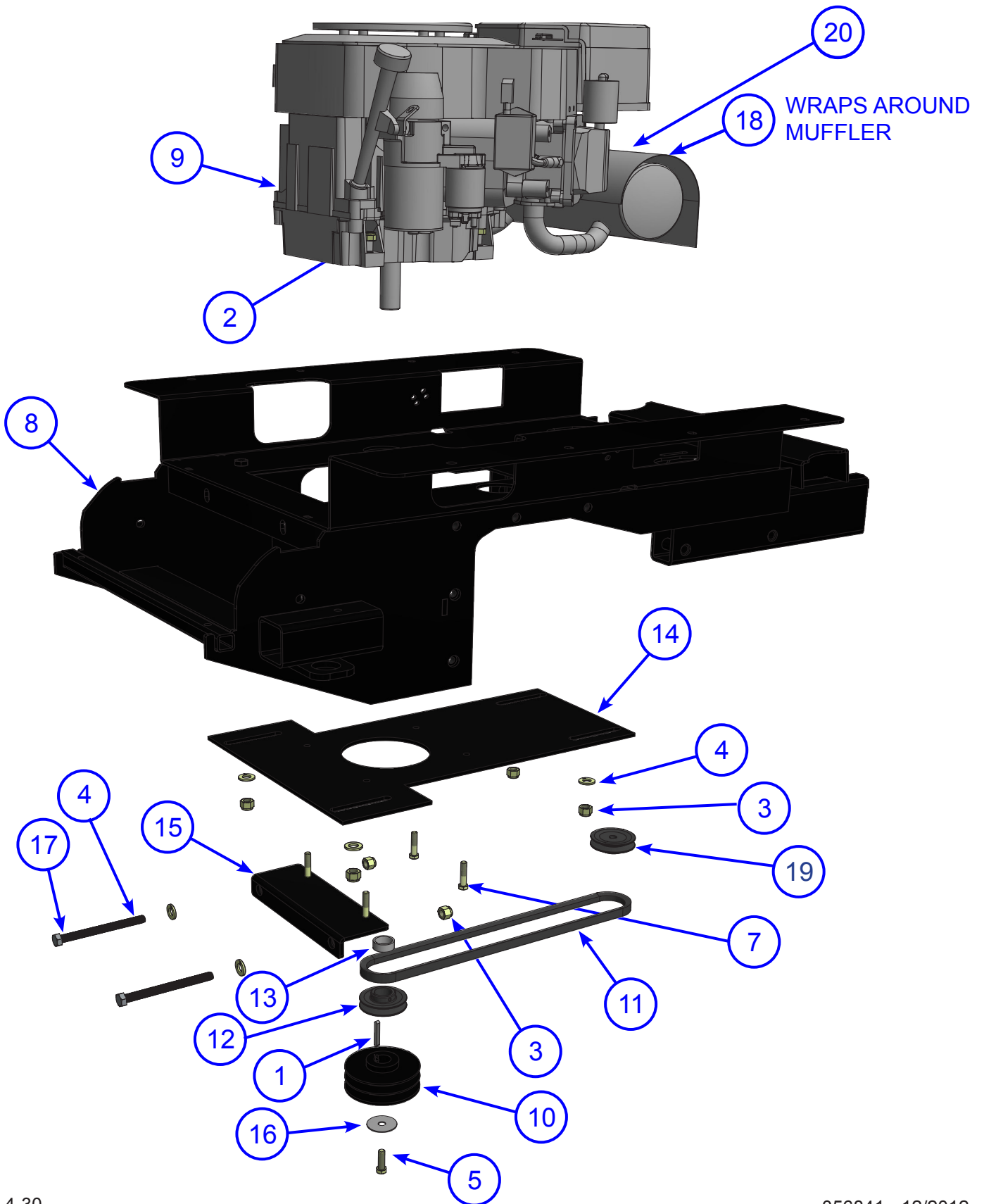

Engine Mount Assembly Parts List

SECTION 4 PARTS

ITEM	PART NO.	DESCRIPTION	QTY
1	010307	KEY, 1/4" X 2" LONG	1
2	010464	FSTN, NUT NYLOK 3/8-16	4
3	011238	FSTN, NUT HEX NYLOK 1/2-13	6
4	011490	FSTN, FW HARDENED 1/2	6
5	017898	FSTN, HHCS 7/16-20 X 1-1/2 GR8	1
6	026775	SCR, 3/8-16x2 GR 8 HHC	2
7	039740	BOLT, 3/8-16 X 2-1/4 GR 8 HHC	2
8	056656	MAIN FRAME WMNT	1
9	056679	KOHLER ENGINE, 27HP VERT	1
10	056773	2BK52 X 1-1/8 FHP SHEAVE	1
11	056810	V-BELT, A45 HI POWER	1
12	056775	PULLEY, AK30X1 1/8	1
13	056782	ENGINE SPACER	1
14	056794	ENGINE ADJ PLATE	1
15	056805	ANGLE F/ ADJ, WMNT	1
16	056875	1/2 X 2 FENDER WASHER	1
17	057539	FSTN, HHCS 1/2-13 X 5 1/2" LONG TAP BOLT	2
18	056938	HEAT SHIELD, 14"X20"	1
19	046550	PULLY, AK30 X 1/2	1
20	066789	HEAT SHIELD	1

SECTION 4 PARTS

Stand Assembly Illustration

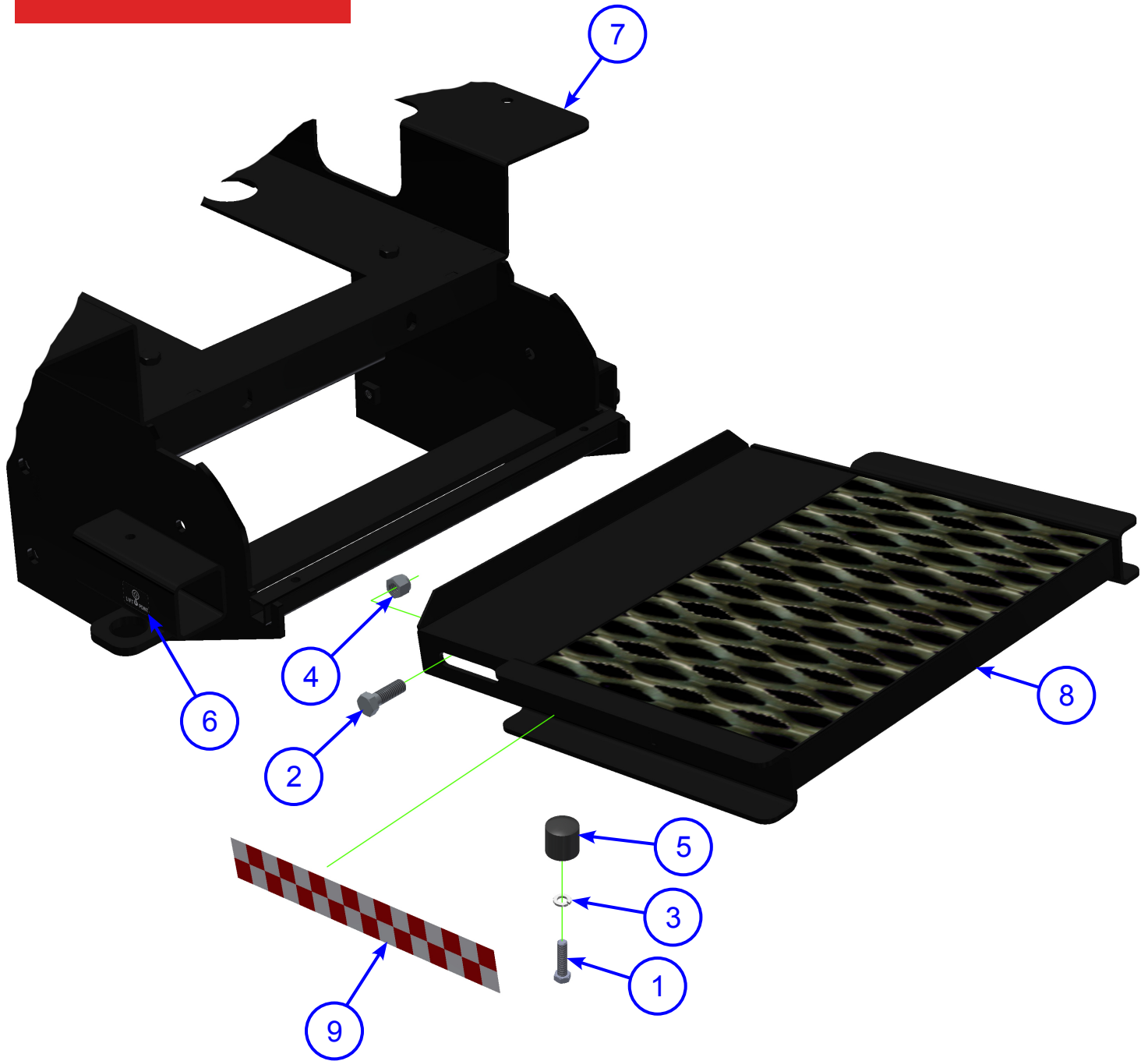

Stand Assembly Parts List

SECTION 4 PARTS

ITEM	PART NO.	DESCRIPTION	QTY
1	010038	BOLT, 3/8-16x1-1/2 GR 5 HHCS	2
2	010069	FSTN, HHCS 1/2-13 X 1-1/2	2
3	010091	FSTN, LW 3/8	2
4	011238	FSTN, NUT HEX NYLOK 1/2-13	2
5	048423	RUBBER BUMPER	2
6	052801	DECAL, LIFT POINT TRACK BUGGY	2
7	056656	MAIN FRAME WMNT, TRACK BUGGY	1
8	056696	OPERATOR PLATFORM F/TRACK BUGGY	1
9	DE2700	DECAL, CHECK STRIPE 1-1/2" X 12" LG	2

VISIT US!!!



www.alleneng.com

LIKE US!!!



www.facebook.com/AllenEngineering

FOLLOW US!!!



[@alleneng](https://twitter.com/alleneng)

WATCH US!!!



www.youtube.com/AllenMachinery

SECTION 4 PARTS

Track Assembly Illustration

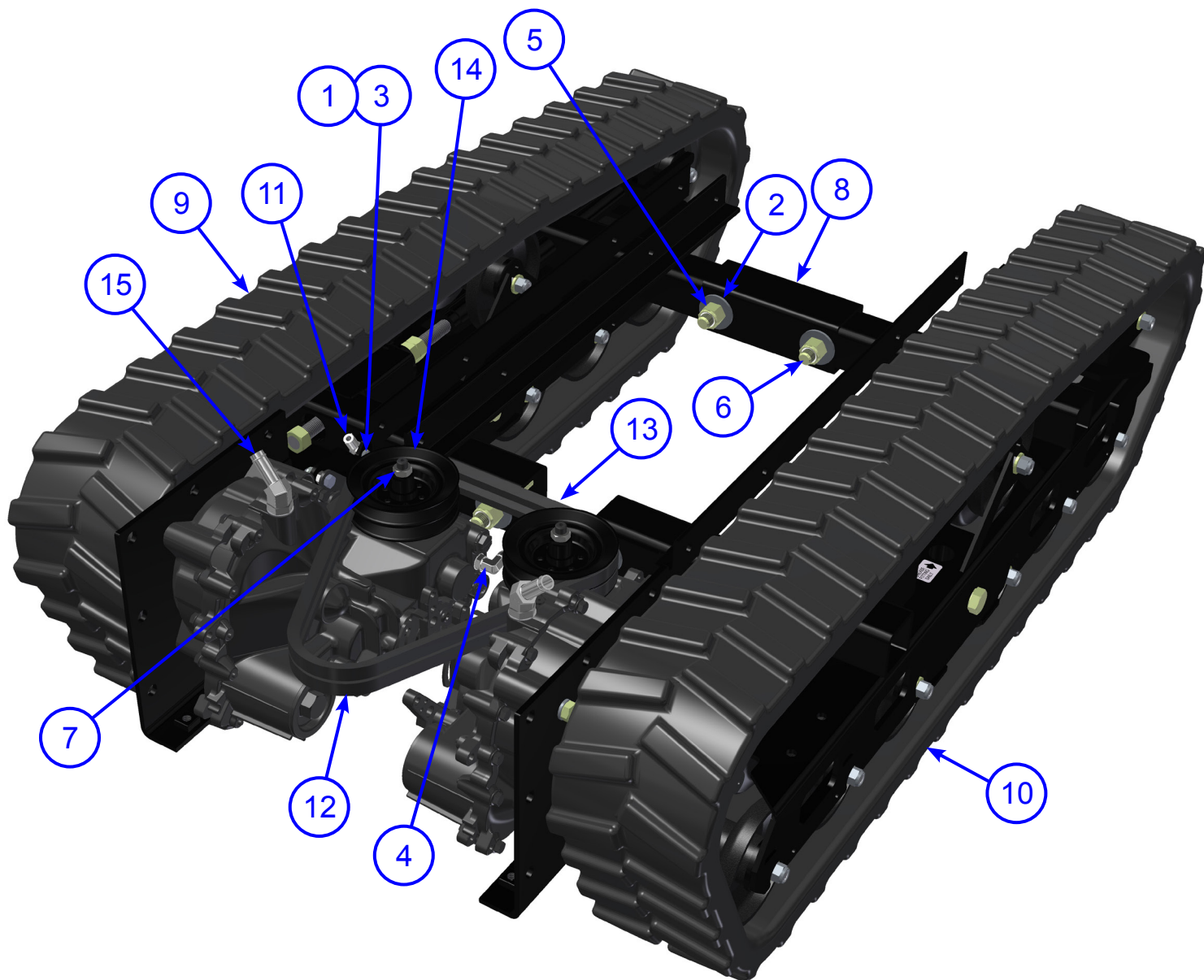

Track Assembly Parts List

SECTION 4 PARTS

ITEM	PART NO.	DESCRIPTION	QTY
1	010003	FSTN, HHCS 1/4-20 X 1	2
2	010087	FSTN, FW 3/4	4
3	020542	FSTN, NUT STOVER LOCK 1/4-20	2
4	045952	FTG, F6801-6-6-NWO 90° ELB	2
5	049351	FSTN, NUT 3/4-10 GR 8 NYLOCK HEX	4
6	050237	FSTN, HHCS 3/4-10 X 4 1/2" GRADE 8 ZINC	4
7	052799	FSTN, NUT HEX JAM 1/2-13	2
8	056638	CROSS MEMBR F/ FRAME	1
9	056674	TRACK ASSEMBLY, LH	1
10	056677	TRACK ASSEMBLY, RH	1
11	056771	BALL JOINT, 1/4"	2
12	056774	BELT, BX-41	2
13	056925	ANGLE FOR CABLES	1
14	056943	PULLEY, 2-GROOVE	2
15	052887	FITTING, 4603-10-10	2

SECTION 4 PARTS

Fuel Assembly Illustration

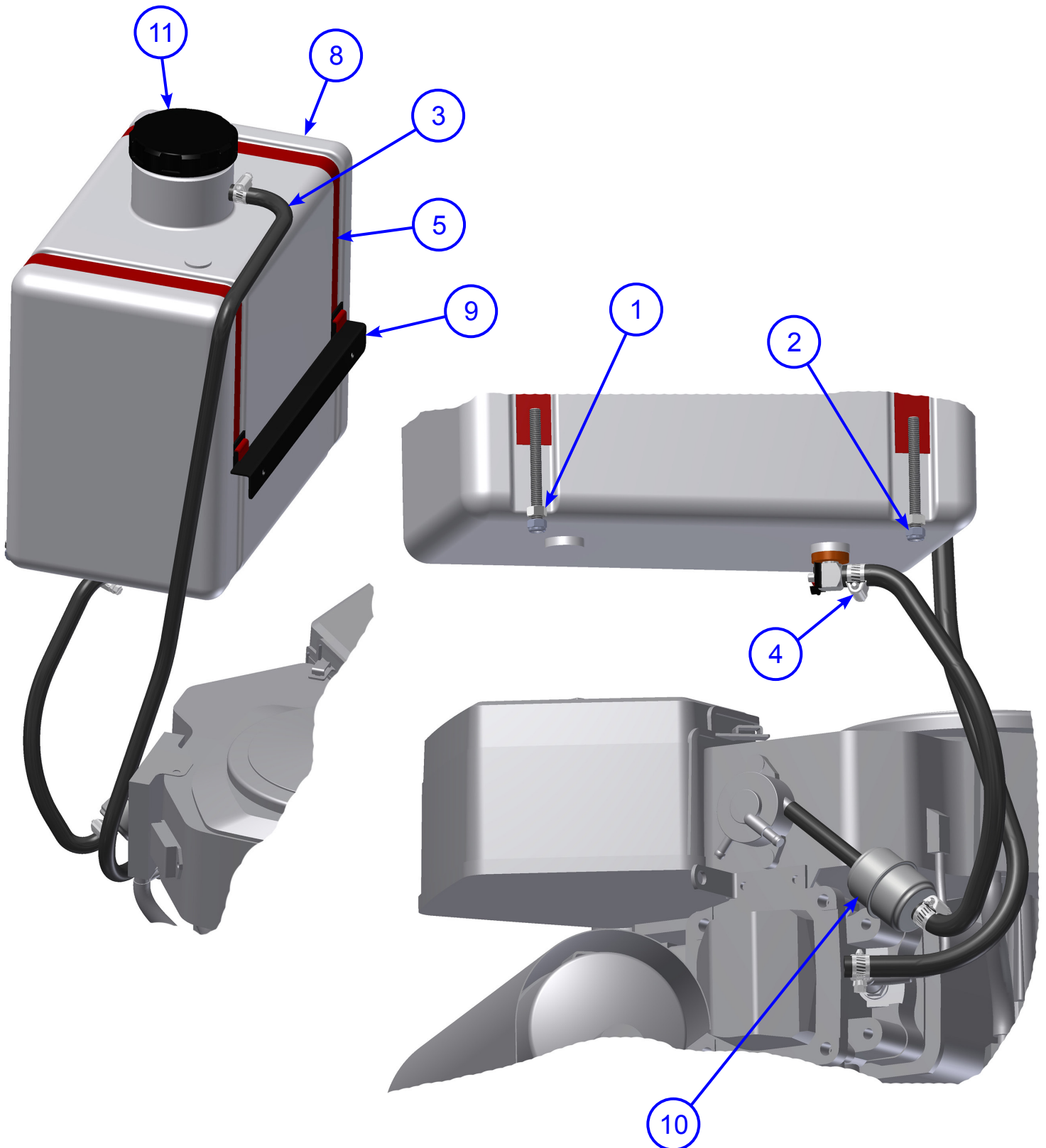

Fuel Assembly Parts List

SECTION 4 PARTS

ITEM	PART NO.	DESCRIPTION	QTY
1	010100	FSTN, NUT HEX 5/16-18	2
2	012612	FSTN, NUT HEX NYLOCK 5/16-18	2
3	019429	HOSE, 5/16" FUEL LINE	41"
4	019430	FSTN, CLAMP SIZE 4 MINI	3
5	048921	STRAP, TANK MSP425	2
6	049035	CAP, 3-1/2" VENTED BLACK	1
7	056679	KOHLER ENGINE, 27HP VERT	1
8	056749	TANK, 6 GALLON GAS, EPA, W/CAP	1
9	056753	TANK MNT BRKT	1
10	057993	FUEL FILTER REPLACEMENT	1
11	053213	CAP F/ TANK, EPA (REPLACEMENT)	



SECTION 4 PARTS

Control Panel Assembly Illustration

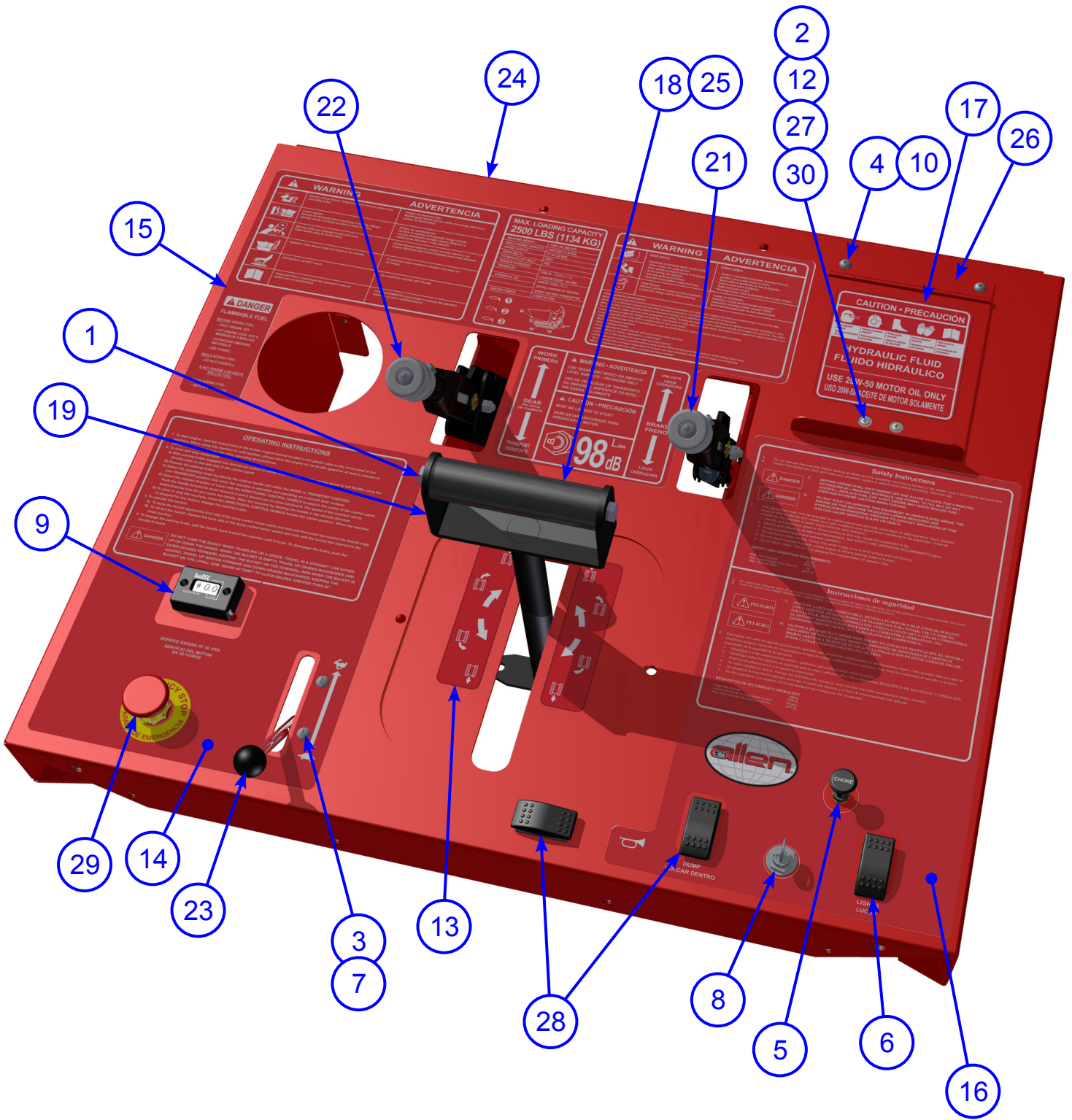

Control Panel Assembly Parts List

SECTION 4 PARTS

ITEM	PART NO.	DESCRIPTION	QTY
1	010035	FSTN, HHCS 3/8-16 X 3/4	2
2	059602	FSTN, PPHS 6-32 X 3/8"	2
3	029568	NUT, 10-32 NYLOCK HEX	2
4	020542	FSTN, NUT HEX 1/4-20 NYLOC	4
5	029928	CHOKE CABLE ASSEMBLY	1
6	032125	SWITCH, ROCKER #91B2184	1
7	034618	SCR #10-32 X1	2
8	039750	KEY SWITCH, KOHLER ENGINE	1
9	042036	METER, TACH/HOUR INDUCTIVE	1
10	042343	FSTN, SFBHCS 1/4"-20 x 3/4	2
11	048929	BEARING, Ø3/4 ID PLASTIC FLANGE	2
12	059603	FSTN, 3/8 STAR LOCK WASHER	2
13	052795	DECAL, TURN TRACK BUGGY	2
14	052796	DECAL, TOP PANEL 3 TRACK BUGGY	1
15	052806	DECAL, TOP PANEL 1 TRACK BUGGY	1
16	052807	DECAL, TOP PANEL 2 TRACK BUGGY	1
17	052808	DECAL, HYDRAULIC FLUID TRACK BUGGY	1
18	056407	HANDLE F/ STEERING	1
19	056408	STEERING HANDLE WMNT	1
20	056744	HSNG WMNT F/ STEERING	1
21	056764	BRAKE LEVER	1
22	056766	HI-LOW LEVER	1
23	056767	THROTTLE CABLE	1
24	056781	TOP COVER WMNT	1
25	056874	FOAM HANDLE GRIP	1
26	056919	DOOR WMNT	1
27	056920	MAGNETIC LATCH	1
28	059525	SWITCH, ROCKER 2-way	2
29	45049-25	EMERGENCY KILL SWITCH	1
30	059604	FSTN, NUT HEX 6-32	2

SECTION 4 PARTS

Bucket Assembly Illustration

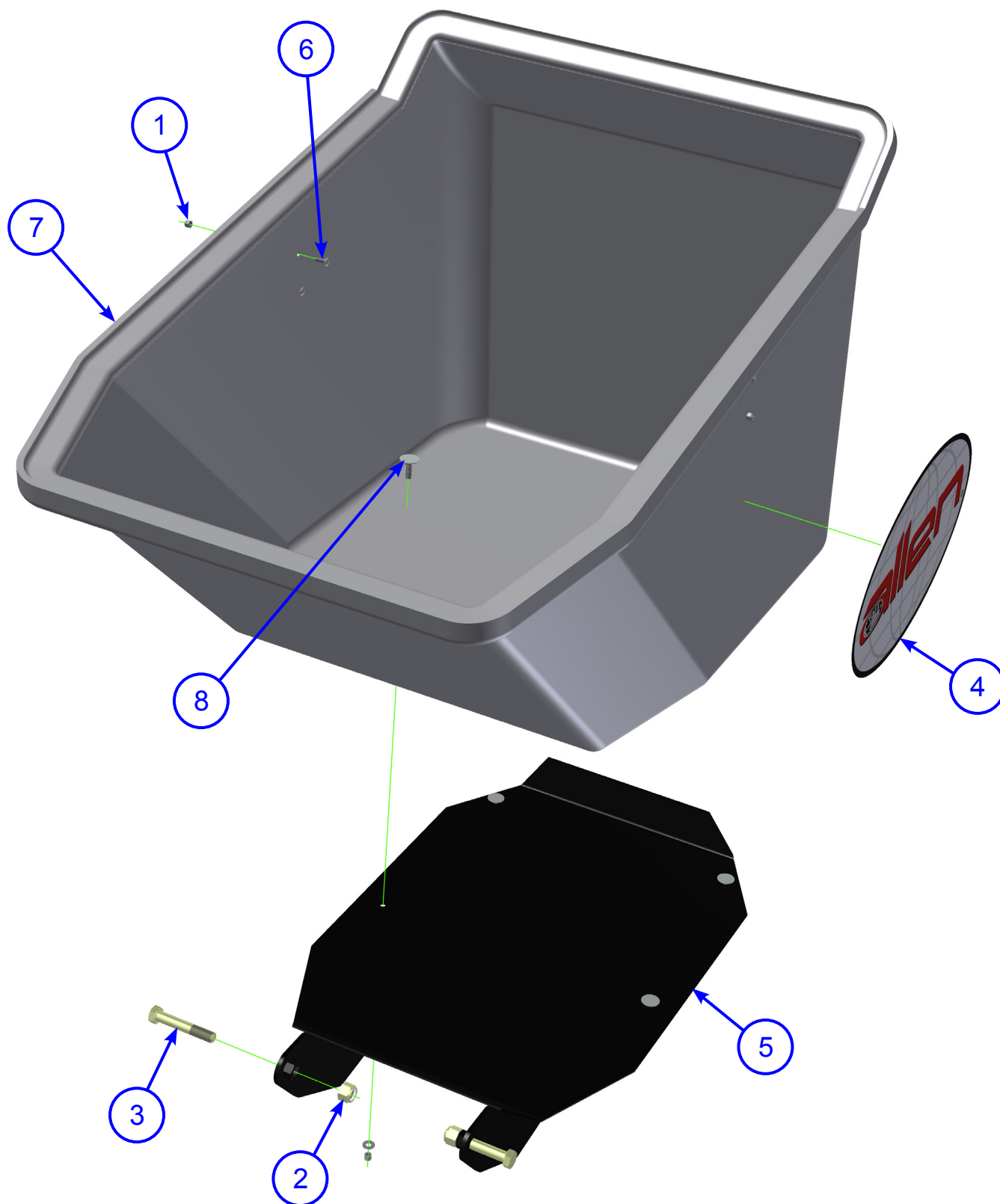

Bucket Assembly Parts List

SECTION 4 PARTS

ITEM	PART NO.	DESCRIPTION	QTY
1	020542	FSTN, NUT HEX 1/4-20 NYLOC	4
2	049351	FSTN, NUT 3/4-10 GR 8 NYLOCK HEX	2
3	050237	FSTN, HHCS 3/4-10 X 4 1/2" GRADE 8 ZINC	2
4	056400	DECAL, 20" OVAL ALLEN	2
5	056646	MB-16/21 BUCKET BASE	1
6	042343	FSTN, SFBHCS 1/4"-20 x 3/4	4
7	42106-01	PLASTIC BUCKET, 16 CU FT	1
8	42106-02	BOLT, ELEVATOR ASSY (NUT,WASHER,BOLT)	4

SECTION 4 PARTS

Skid Plate Assembly Illustration and Parts List

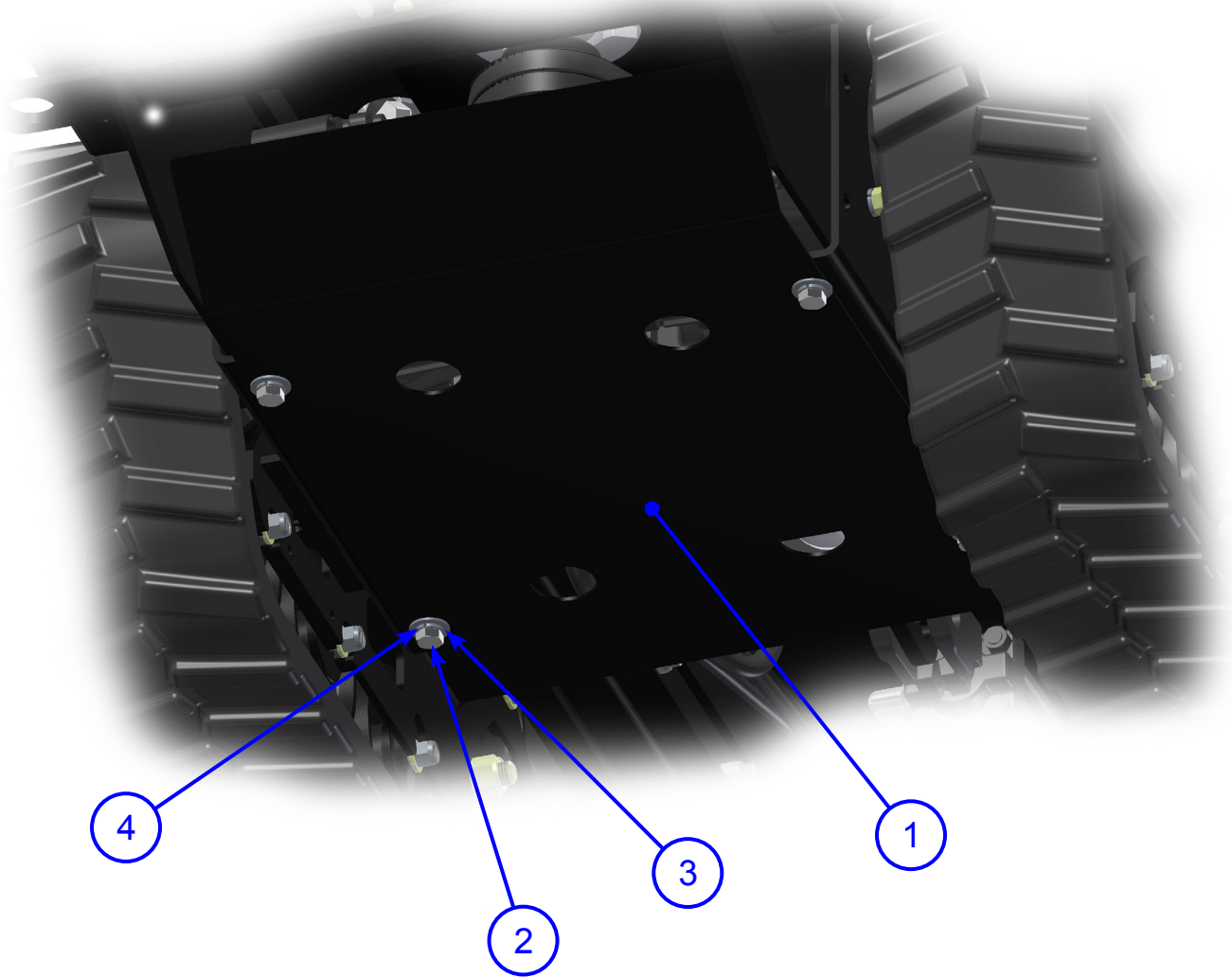

ITEM	PART NO.	DESCRIPTION	QTY
1	056929	SKID PLATE	1
2	010067	FSTN, HHCS 1/2-13 X 1	4
3	010085	FSTN, FW 1/2	4
4	010093	FSTN, LW 1/2	4

Handle Bar Assembly Illustration and Parts List

SECTION 4 PARTS

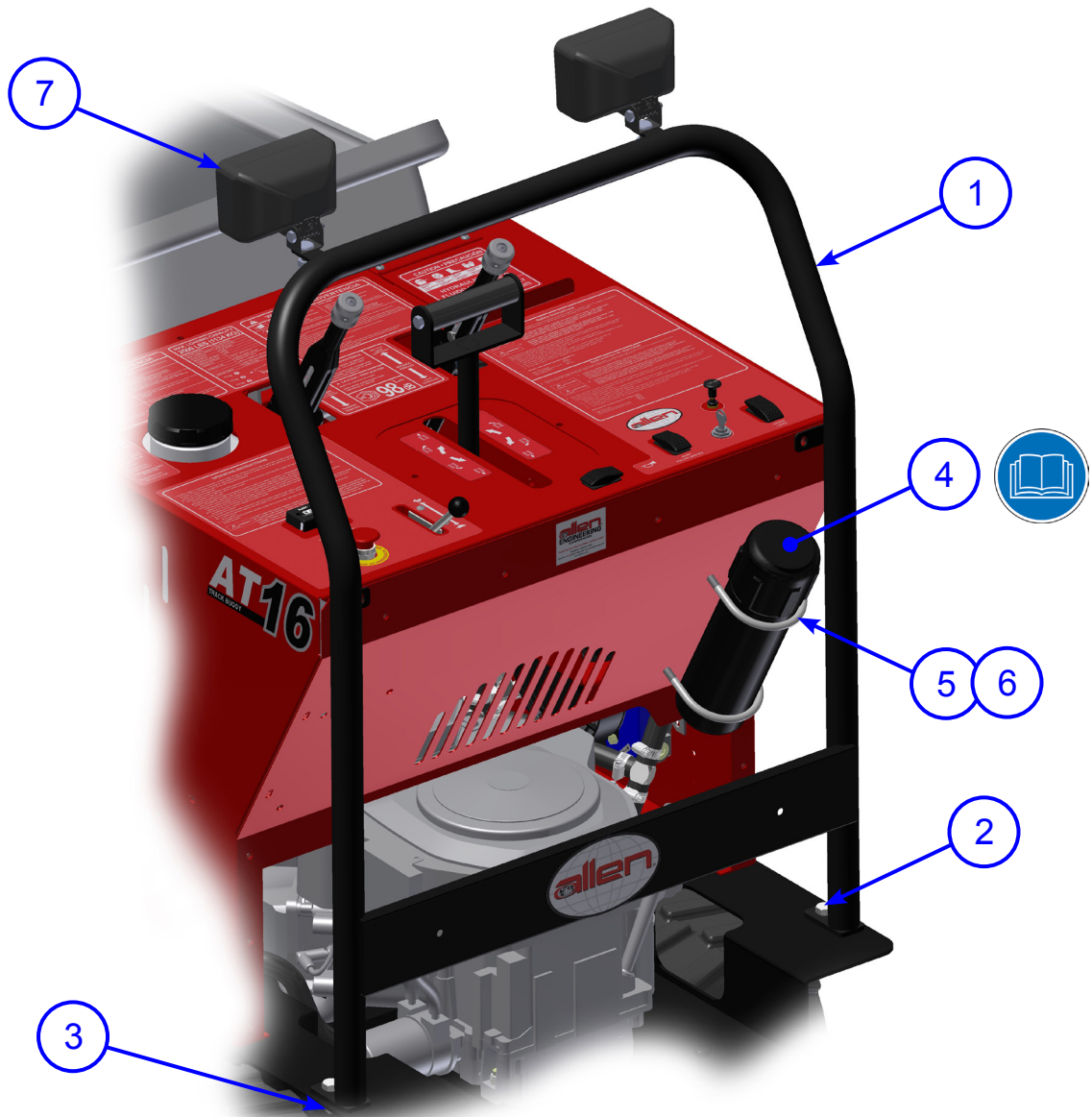

ITEM	PART NO.	DESCRIPTION	QTY
1	056385	HANDLE BAR WMNT	1
2	010068	FSTN, HHCS 1/2-13 X 1-1/4 GR 5	2
3	011238	FSTN, NUT HEX NYLOK 1/2-13	2
4	048665	TUBE, MANUAL PACK PLASTIC 9000-14	1
5	053189	FSTN, U-BOLT - 3-1/2"	2
6	010102	FSTN, NUT HEX 3/8-16	4
7	036881	LIGHT, PREP F/ RIDING TROWELS	2

SECTION 4 PARTS

Decal Layout (right side) Illustration

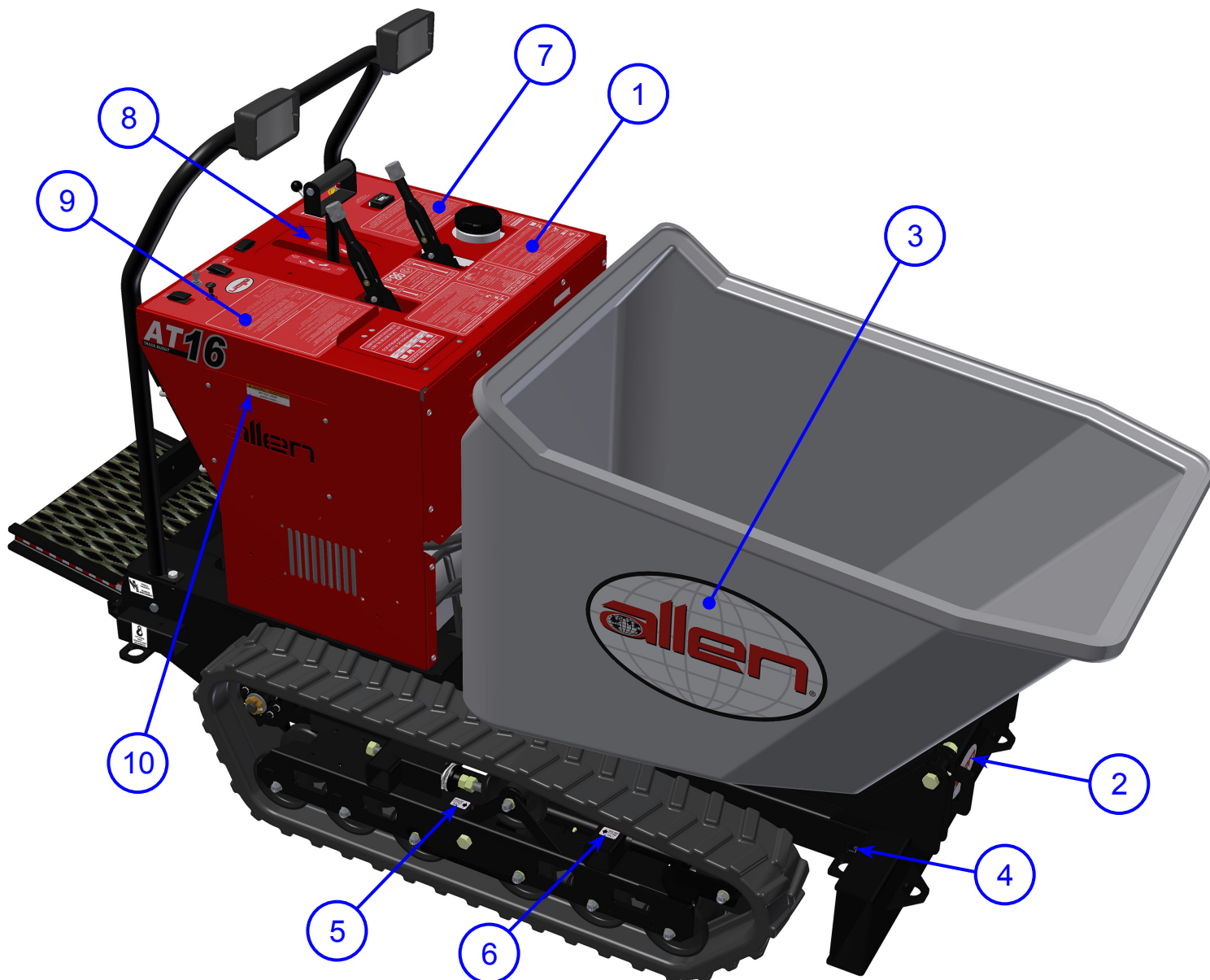

ITEM	PART NO.	DESCRIPTION	QTY
1	052806	DECAL, TOP PANEL 1 TRACK BUGGY	1
2	056340	DECAL ALLEN OVAL 4" X 6.67" WHITE	1
3	056400	DECAL, 20" OVAL ALLEN	2
4	053448	DECAL, LIFT HERE ONLY (SP)	4
5	052803	DECAL, RIGHT ARROW GREASE FITTING	2
6	052802	DECAL, LEFT ARROW GREASE FITTING	2
7	052796	DECAL, TOP PANEL 3 TRACK BUGGY	1
8	052795	DECAL, TURN TRACK BUGGY	1
9	052807	DECAL, TOP PANEL 2 TRACK BUGGY	1
10	052805	DECAL, BATTERY INSIDE TRACK BUGGY	1

Decal Layout (left side) Illustration

SECTION 4 PARTS



ITEM	PART NO.	DESCRIPTION	QTY
1	052808	DECAL, HYDRAULIC FLUID TRACK BUGGY	1
2	056340	DECAL ALLEN OVAL 4" X 6.67" WHITE	1
3	DE2700	DECAL, CHECK STRIPE 1-1/2" X 12" LG	2
4	052800	DECAL, AT16 TRACK BUGGY	2
5	056338	DECAL AEC 1.5" X 3.25" WHITE/RED	1

**SECTION 4
PARTS****Filter Kit**

ITEM	PART NO.	DESCRIPTION	QTY
A	066445	KIT, AT16 BUGGY FILTER	
1	057991	AIR FILTER CH-1000 40 KHLR 6208304-S	1
2	057992	FOAM AIR P-CLNR CH-1000 40 6208303-S	1
3	057994	OIL FILTER CH-1000 40KOLR 5205002-S1	1
4	046730	FILTER ELEMENT SF 6310-18	1
5	057993	FUEL FILTER CH-1000 40KHR 2405013-S1	1



INTENTIONALLY BLANK

allen[®]
ENGINEERING
CORPORATION

P.O. BOX 819 PARAGOULD, AR 72451 USA

800.643.0095 (USA ONLY) / 870.236.7751

FAX: 800.643.0097 (USA ONLY) / 870.236.3934

WWW.ALLENENG.COM

CONNECT WITH US ON

